

## SWITCHING POWER SUPPLY

480W Single Output Industrial DIN RAIL



### Features

- Universal AC input / Full range
- Built-in active PFC function
- Protections: Short circuit / Overload / Over voltage / Over temperature
- Cooling by free air convection
- Can be installed on DIN rail TS-35/7.5 or 15
- UL 508 (industrial control equipment) approved
- BS EN/EN61000-6-2(BS EN/EN50082-2) industrial immunity level
- 100% full load burn-in test
- 3 years warranty

### Applications

- Industrial control system
- Factory automation
- Electro-mechanical apparatus

## SWITCHING POWER SUPPLY

### 480W Single Output Industrial DIN RAIL

#### Description

MIT-480 is one economical slim 480W Din rail power supply series, adapt to be installed on TS-35/7.5 or TS-35/15 mounting rails. The body is designed 85.5mm in width, which allows space saving inside the cabinets. The entire series adopts the full range AC input from 90VAC to 264VAC and conforms to BS EN/EN61000-3-2, the norm the European Union regulates for harmonic current.

MIT-480 is designed with metal housing that enhances the unit's power dissipation. With working efficiency up to 92.5%, the entire series can operate at the ambient temperature between -20°C and 70°C under air convection. It is equipped with constant current mode for over-load protection, fitting various inductive or capacitive applications. The complete protection functions and relevant certificates for industrial control apparatus (UL508, TUV BS EN/EN62368-1, and etc.) make MIT-480 a very competitive power supply solution for industrial applications.

#### Model Encoding

MIT-480-24

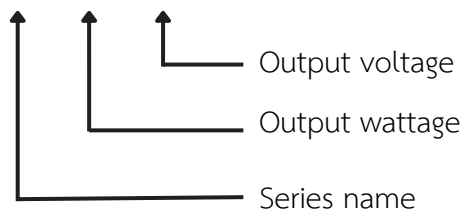

## SWITCHING POWER SUPPLY

### 480W Single Output Industrial DIN RAIL

#### SPECIFICATION

MODEL		MIT-480-24
OUTPUT	DC VOLTAGE	24V
	RATED CURRENT	20A
	CURRENT RANGE	0 ~ 20A
	RATED POWER	480W
	RIPPLE & NOISE (max.) Note.2	150MVP-P
	VOLTAGE ADJ. RANGE	24 ~ 28V
	VOLTAGE TOLERANCE Note.3	±1.0%
	LINE REGULATION	±0.5%
	LOAD REGULATION	±1.0%
	SETUP, RISE TIME	1500MS, 100MS/230VAC 3000MS, 100MS/115VAC AT FULL LOAD
	HOLD UP TIME (Typ.)	16MS/230VAC 16MS/115VAC AT FULL LOAD
INPUT	VOLTAGE RANGE Note.4	90 ~ 264VAC 127 ~ 370VDC
	FREQUENCY RANGE	47 ~ 63HZ
	POWER FACTOR (Typ.)	PF>0.98/115VAC, PF>0.94/230VAC AT FULL LOAD
	EFFICIENCY (Typ.)	92.5%
	AC CURRENT (Typ.)	4.8A/115VAC 2.4A/230VAC
	INRUSH CURRENT (Typ.)	20A/115VAC 35A/230VAC
	LEAKAGE CURRENT	<2MA / 240VAC

## SWITCHING POWER SUPPLY

### 480W Single Output Industrial DIN RAIL

MODEL		MIT-480-24
PROTECTION	OVERLOAD	105 ~ 130% rated output power
		Protection type : Constant current limiting, unit will shut down after 3 sec., re-power on to recover
	OVER VOLTAGE	29 ~ 33V
Protection type : Shut down o/p voltage, re-power on to recover		
	OVER TEMPERATURE	Shut down o/p voltage, recovers automatically after temperature goes down
ENVIRONMENT	WORKING TEMP.	-20 ~ +70°C (Refer to "Derating Curve")
	WORKING HUMIDITY	20 ~ 95% RH non-condensing
	STORAGE TEMP., HUMIDITY	-40 ~ +85°C, 10 ~ 95% RH
	TEMP. COEFFICIENT	±0.03%/°C (0 ~ 50°C)
	VIBRATION	Component:10 ~ 500Hz, 2G 10min./1cycle, 60min. each along X, Y, Z axes; Mounting: Compliance to IEC60068-2-6
SAFETY & EMC (Note 4)	SAFETY STANDARDS	UL508, TUV BS EN/EN62368-1, EAC TP TC 004 , BSMI CNS15598-1 , IS13252(Part1)/IEC60950-1(except for 48V) approved; (meet BS EN/EN60204-1)
	WITHSTAND VOLTAGE	I/P-O/P:3KVAC I/P-FG:2KVAC O/P-FG:0.5KVAC
	ISOLATION RESISTANCE	I/P-O/P, I/P-FG, O/P-FG:>100M Ohms / 500VDC / 25°C/ 70% RH
	EMC EMISSION	Compliance to BS EN/EN55032 (CISPR32),BS EN/EN61204-3 Class B,BS EN/EN61000-3-2,-3,EAC TP TC 020,CNS15936 Class B
	EMC IMMUNITY	Compliance to BS EN/EN61000-4-2,3,4,5,6,8,11,BS EN/EN55035,BS EN/EN61000-6-2 (BS EN/EN50082-2),BS EN/EN61204-3, heavy industry level, EAC TP TC 020

**SWITCHING POWER SUPPLY****480W Single Output Industrial DIN RAIL**

MODEL		MIT-480-24
OTHERS	MTBF	1041.6K hrs min. Telcordia SR-332 (Bellcore) ; 146.8K hrs min. MIL-HDBK-217F (25°C)
	DIMENSION	85.5*125.2*128.5mm (W*H*D)
	PACKING	1.5Kg; 8pcs/13Kg/0.9CUFT
NOTE	<p>1.All parameters NOT specially mentioned are measured at 230VAC input, rated load and 25°C of ambient temperature.</p> <p>2.Ripple &amp; noise are measured at 20MHz of bandwidth by using a 12" twisted pair-wire terminated with a 0.1 <math>\mu</math> F &amp; 47 <math>\mu</math> F parallel capacitor.</p> <p>3.Tolerance : includes set up tolerance, line regulation and load regulation.</p> <p>4.Installation clearances : 40mm on top, 20mm on the bottom, 5mm on the left and right side are recommended when loaded permanently with full power.In case the adjacent device is a heat source, 15mm clearance is recommended.</p> <p>5.Derating may be needed under low input voltage. Please check the derating curve for more details.</p> <p>6.The power supply is considered as an independent unit, but the final equipment still need to re-confirm that the whole system complies with the EMC directives. For guidance on how to perform these EMC tests, please refer to "EMI testing of component power supplies."</p> <p>7.The ambient temperature derating of 3.5°C/1000m with fanless models and of 5°C/1000m with fan models for operating altitude higher than 2000m(6500ft).</p>	

# SWITCHING POWER SUPPLY

## 480W Single Output Industrial DIN RAIL

### Block Diagram

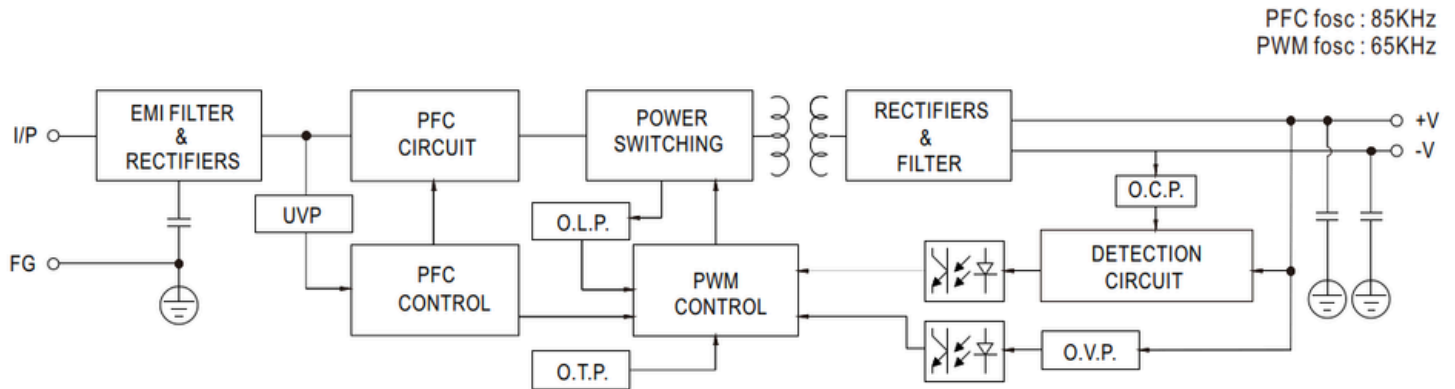

### Derating Curve

### Output derating VS input voltage

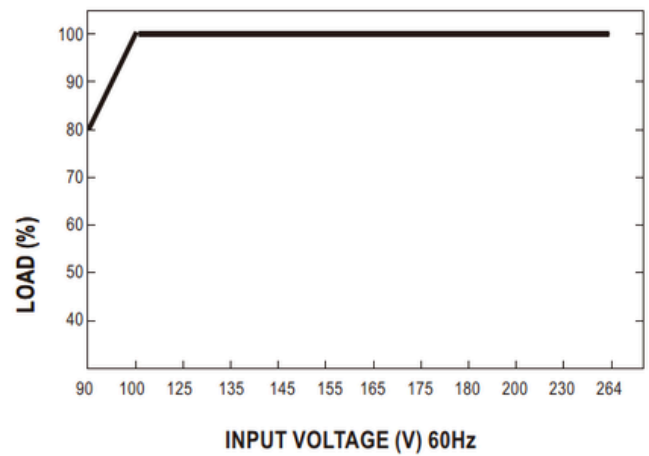
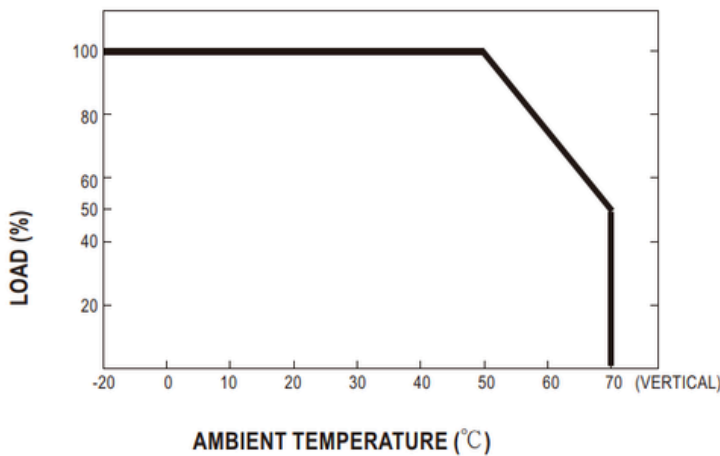

# SWITCHING POWER SUPPLY

## 480W Single Output Industrial DIN RAIL

### Mechanical Specification

(Unit: mm , tolerance  $\pm 1$ mm)

Case No.984D

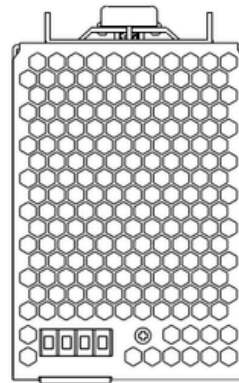

Top View

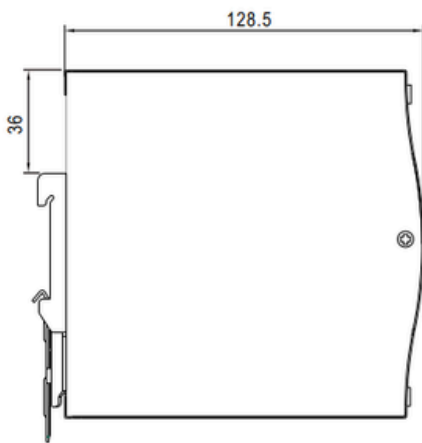

Side View

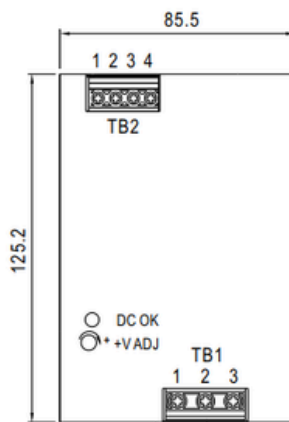

Front View

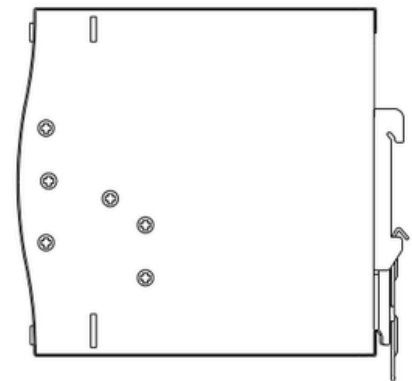

Side View

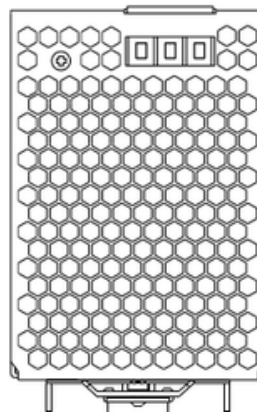

Bottom View

#### Terminal Pin No. Assignment (TB1)

Pin No.	Assignment
1	FG $\oplus$
2	AC/N or DC -
3	AC/L or DC +

#### Terminal Pin No. Assignment (TB2)

Pin No.	Assignment
1,2	DC OUTPUT +V
3,4	DC OUTPUT-V

# SWITCHING POWER SUPPLY

## 480W Single Output Industrial DIN RAIL

### Installation Instruction

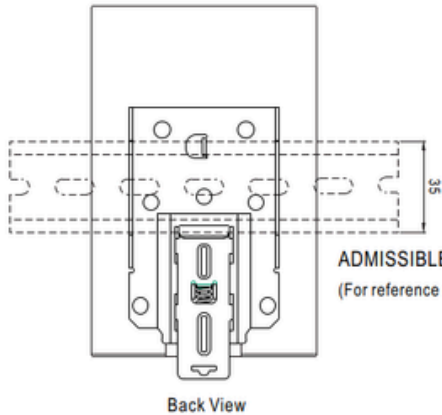

This series fits DIN rail TS35/7.5 or TS35/15.  
For installation details, please refer to the Instruction manual.

### Installation Manual

1. Always allow good ventilation clearances, 5mm left and right, 40mm above and 20mm below, around the unit in use to prevent it from overheating. Also a 10-15 cm clearance must be kept when the adjacent device is a heat source.
2. The appropriate mounting orientation for the unit is vertical, the input terminals at the bottom and output on the top. Mounting orientations other than that, such as upside down, horizontal, or table-top mounting, is not allowed.
3. Use copper wire only, and recommended wires are shown as below.

AWG	18	16	14	12
Rated Current of Equipment (Amp)	7A	10A	15A	20A
Cross-section of Lead(mm <sup>2</sup> )	0.8	1.3	2.1	3.3

Note:  
Current each wire carries should be de-rated to 80% of the current suggested above when using 5 or more wires connected to the unit.

Make sure that all strands of each stranded wire enter the terminal connection and the screw terminals are securely fixed to prevent poor contact. If the power supply possesses multi-output terminals, please make sure each contact is connected to wires to prevent too much current stress on a single contact.

# SWITCHING POWER SUPPLY

## 480W Single Output Industrial DIN RAIL

4. Use wires that can withstand temperatures of at least 80°C, such as UL1007.
5. Recommended wire strapping length is 5mm (0.197").
6. Recommended screwdriver is 3mm, slotted type.
7. The recommended torque setting for terminals is shown as below.

Model	I/P	O/P
MIT-120	7.5 kgf-cm (6.5 Lb-in)	7.5 kgf-cm (6.5 Lb-in)
MIT-240	7.5 kgf-cm (6.5 Lb-in)	7.5 kgf-cm (6.5 Lb-in)
MIT-480	10.35 kgf-cm (9 Lb-in)	10.35 kgf-cm (9 Lb-in)

8. Suggested fuse and maximum number of the PSUs that can be connected to a circuit breaker at 230V are shown as below.

Model	Fuse	Circuit breakerC16	Circuit breakerD16
MIT-120	T4A/L250V	5	10
MIT-240	T5A/L250V	4	10
MIT-480	T8A/L250V	3	5

9. Mounting Instruction :Mount as shown in figure only, with input terminals down, or else sufficient cooling will not be possible.

Admissible DIN rail : TS35/7.5 or TS35/15

For rail fastening : 

- ( a ) Tilt the unit slightly rearwards.
- ( b ) Fit the unit over top hat rail.
- ( c ) Slide it downward until it hits the stop.
- ( d ) Press against the bottom for locking.
- ( e ) Shake the unit slightly to check the locking action.

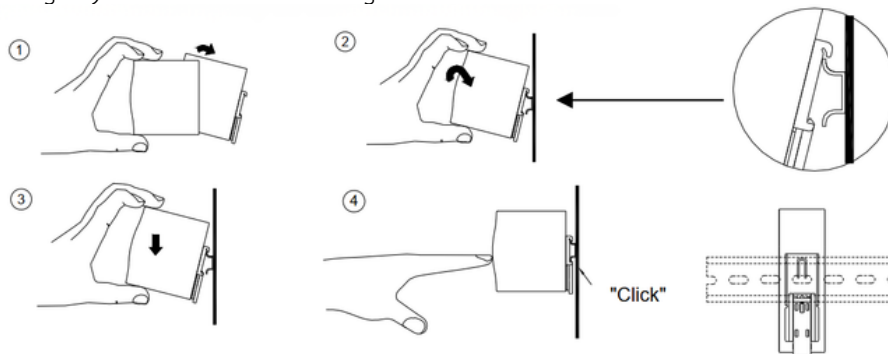

## SWITCHING POWER SUPPLY

### 480W Single Output Industrial DIN RAIL

#### Warning / Caution !!

1. Risk of electrical shock and energy hazard. All failure should be examined by a qualified technician.  
Please do not remove the case of the power supply by yourself!
2. Risk of electric arcs and electric shock (danger to life). Connecting both the primary and the secondary sides together is not allowed.
3. Risk of burn hazard. Do not touch the unit in operation and shortly after disconnection!
4. Risk of fire and short circuit. The openings should be protected from foreign objects or dripping liquids.
5. Only install the unit in a pollution degree 2 environment (Note.1).
6. Please do not install the unit in places with high moisture or near the water.
7. The maximum operating temperature is 50°C for MIT-120-24, MIT-240-24, MIT-480-24, please do not install the unit in places with high ambient temperature or near fire source.
8. The FG (  $\perp$  ) must be connected to PE (Protective Earth).
9. Output current and output wattage must not exceed the rated value on its specification.
10. Disconnect system from supply voltage: Before commencing any installation, maintenance or modification work: Disconnect your system from supply voltage. Make sure that inadvertent connection in circuit will be impossible!
11. For continued protection against risk of fire, replace only with same type and rating of fuse. Pour ne pas compromettre la protection contre les risqué d'incendie, remplacer par un fusible de même type et de memes caractéristiques nominales.

Note.1: Pollution Degree 2 applies where there is only non-conductive pollution that might temporarily become conductive due to occasional condensation. Generally refer to dry, well-ventilated locations, such as control cabinets.



Thank you



Website



LINE Official

Website : [www.mit-trade.com](http://www.mit-trade.com)  
Email : [info.mittrade@gmail.com](mailto:info.mittrade@gmail.com)  
Phone : 081-123-2475



081-123-2475



Line id: mitttrade



[www.mit-trade.com](http://www.mit-trade.com)



[info.mittrade@gmail.com](mailto:info.mittrade@gmail.com)