

SWITCHING POWER SUPPLY

120W Single Output Industrial DIN RAIL



Features

- Universal AC input / Full range
- Protections: Short circuit / Overload / Over voltage / Over temperature
- Cooling by free air convection
- Can be installed on DIN rail TS-35/7.5 or 15
- UL 508 (industrial control equipment) approved
- BS EN/EN61000-6-2(BS EN/EN50082-2) industrial immunity level
- 100% full load burn-in test
- 3 years warranty

Applications

- Industrial control system
- Semiconductor fabrication equipment
- Factory automation
- Electro-mechanical apparatus

SWITCHING POWER SUPPLY

120W Single Output Industrial DIN RAIL

Description

MIT-120 is one economical slim 120W DIN rail power supply series, adapt to be installed on TS-35/7.5 or TS-35/15 mounting rails. The body is designed 40mm in width, which allows space saving inside the cabinets. The entire series adopts the full range AC input from 90VAC to 264VAC and conforms to BS EN/EN61000-3-2, the norm the European Union regulates for harmonic current.

MIT-120 is designed with metal housing that enhances the unit's power dissipation. With working efficiency up to 89%, the entire series can operate at the ambient temperature between -20°C and 70°C under air convection. It is equipped with constant current mode for over-load protection, fitting various inductive or capacitive applications. The complete protection functions and relevant certificates for industrial control apparatus (UL508, TUV BS EN/EN62368-1, and etc.) make MIT-120 a very competitive power supply solution for industrial applications.

Model Encoding

MIT-120-24

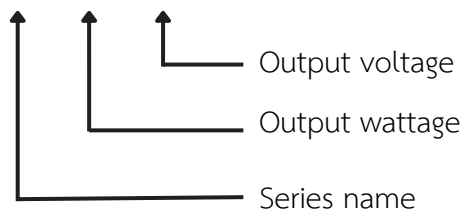

SWITCHING POWER SUPPLY

120W Single Output Industrial DIN RAIL

SPECIFICATION

MODEL		MIT-120-24
OUTPUT	DC VOLTAGE	24V
	RATED CURRENT	5A
	CURRENT RANGE	0 ~ 5A
	RATED POWER	120W
	RIPPLE & NOISE (max.) Note.2	120mVp-p
	VOLTAGE ADJ. RANGE	24 ~ 28V
	VOLTAGE TOLERANCE Note.3	±1.0%
	LINE REGULATION	±0.5%
	LOAD REGULATION	±1.0%
	SETUP, RISE TIME	1200ms, 60ms/230VAC 2500ms, 60ms/115VAC at full load
HOLD UP TIME (Typ.)	16ms/230VAC 10ms/115VAC at full load	
INPUT	VOLTAGE RANGE Note.6	90 ~ 264VAC 127 ~ 370VDC [DC input operation possible by connecting AC/L(+), AC/N(-)]
	FREQUENCY RANGE	47 ~ 63Hz
	EFFICIENCY (Typ.)	88%
	AC CURRENT (Typ.)	2.25A/115VAC 1.3A/230VAC
	INRUSH CURRENT (Typ.)	20A/115VAC 35A/230VAC
	LEAKAGE CURRENT	<1mA / 240VAC

SWITCHING POWER SUPPLY

120W Single Output Industrial DIN RAIL

MODEL		MIT-120-24
PROTECTION	OVERLOAD	105 ~ 130% rated output power
		Protection type : Constant current limiting, recovers automatically after fault condition is removed
	OVER VOLTAGE	29 ~ 33V
		Protection type : Shut down o/p voltage, re-power on to recover
OVER TEMPERATURE	Shut down o/p voltage, re-power on to recover	
ENVIRONMENT	WORKING TEMP.	-20 ~ +70°C (Refer to "Derating Curve")
	WORKING HUMIDITY	20 ~ 95% RH non-condensing
	STORAGE TEMP., HUMIDITY	-40 ~ +85°C, 10 ~ 95% RH
	TEMP. COEFFICIENT	±0.03%/°C (0 ~ 50°C)
	VIBRATION	Component:10 ~ 500Hz, 2G 10min./1cycle, 60min. each along X, Y, Z axes; Mounting: Compliance to IEC60068-2-6
SAFETY & EMC (Note 4)	SAFETY STANDARDS	UL508, TUV BS EN/EN62368-1, EAC TP TC 004 approved;(meet BS EN/EN6204-1)
	WITHSTAND VOLTAGE	I/P-O/P:3KVAC I/P-FG:2KVAC O/P-FG:0.5KVAC
	ISOLATION RESISTANCE	I/P-O/P, I/P-FG, O/P-FG:>100M Ohms / 500VDC / 25°C / 70% RH
	EMC EMISSION	Compliance to BS EN/EN55032 (CISPR32), BS EN/EN61204-3 Class B, BS EN/EN61000-3-2,-3, EAC TP TC 020
	EMC IMMUNITY	Compliance to BS EN/EN61000-4-2,3,4,5,6,8,11, BS EN/EN55035, BS EN/EN61000-6-2 (BS EN/EN50082-2), BS EN/EN61204-3, heavy industry level, EAC TP TC 020

**SWITCHING POWER SUPPLY****120W Single Output Industrial DIN RAIL**

MODEL		MIT-120-24
OTHERS	MTBF	2636.8K hrs min. Telcordia SR-332 (Bellcore) ; 453.3K hrs min. MIL-HDBK-217F (25°C)
	DIMENSION	40*125.2*113.5mm (W*H*D)
	PACKING	0.6Kg; 20pcs/13Kg/1.16CUFT
NOTE	<p>1. All parameters NOT specially mentioned are measured at 230VAC input, rated load and 25°C of ambient temperature.</p> <p>2. Ripple & noise are measured at 20MHz of bandwidth by using a 12" twisted pair-wire terminated with a 0.1 μ F & 47 μ F parallel capacitor.</p> <p>3. Tolerance : includes set up tolerance, line regulation and load regulation.</p> <p>4. The power supply is considered a component which will be installed into a final equipment. The final equipment must be re-confirmed that it still meets EMC directives.</p> <p>5. Installation clearances : 40mm on top, 20mm on the bottom, 5mm on the left and right side are recommended when loaded permanently with full power. In case the adjacent device is a heat source, 15mm clearance is recommended.</p> <p>6. Derating may be needed under low input voltage. Please check the derating curve for more details.</p> <p>7. The ambient temperature derating of 3.5°C/1000m with fanless models and of 5°C/1000m with fan models for operating altitude higher than 2000m(6500ft).</p>	

SWITCHING POWER SUPPLY

120W Single Output Industrial DIN RAIL

Block Diagram

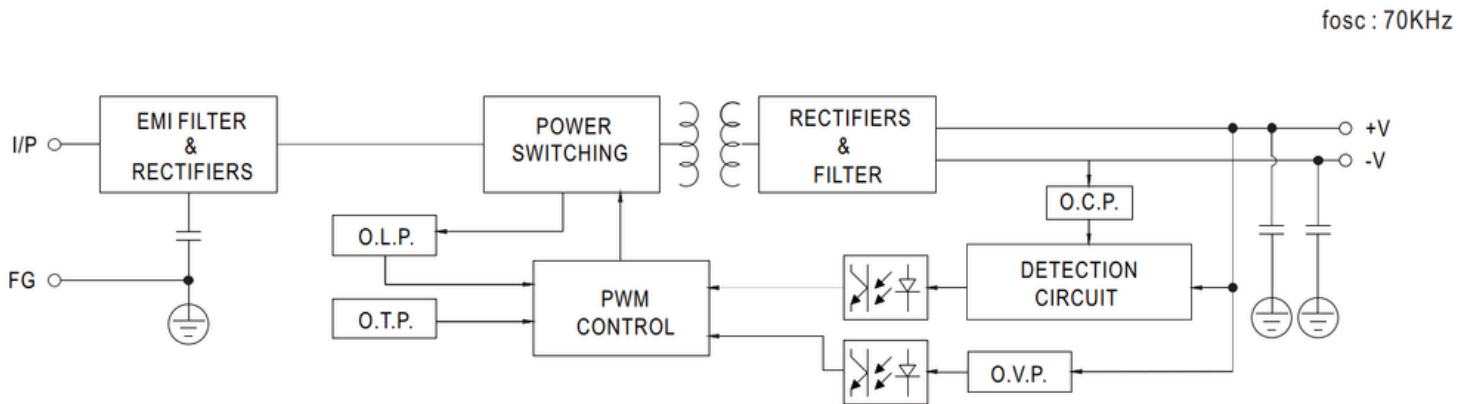

Derating Curve

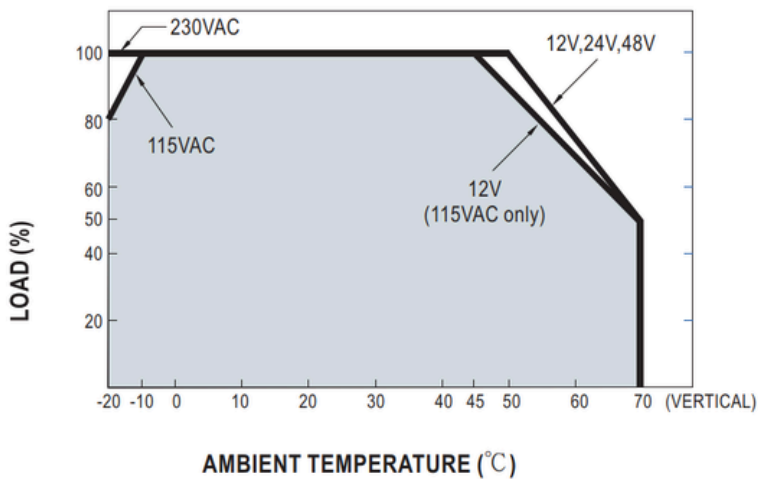

Static Characteristics

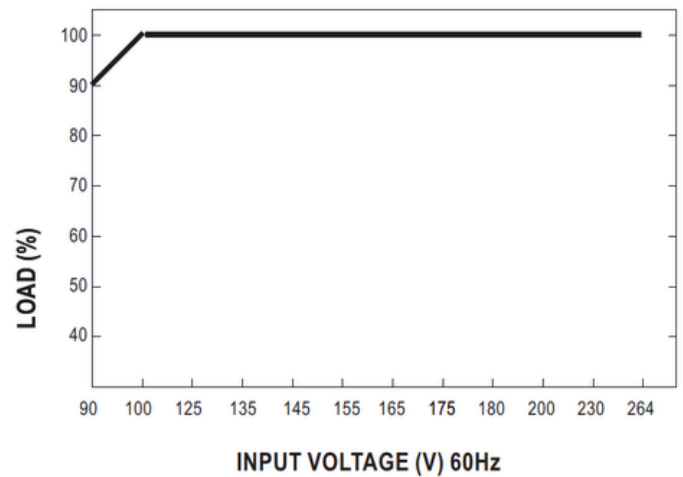

SWITCHING POWER SUPPLY

120W Single Output Industrial DIN RAIL

Mechanical Specification

Case No.992D Unit:mm

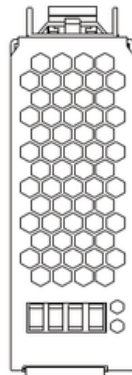

Top View

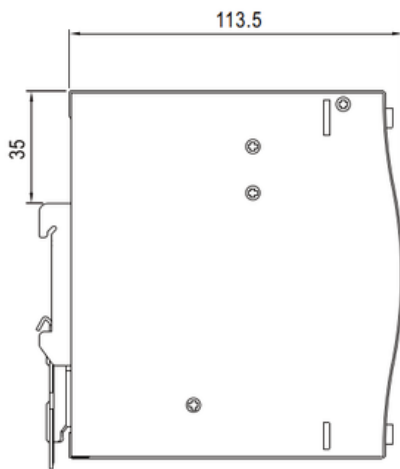

Side View

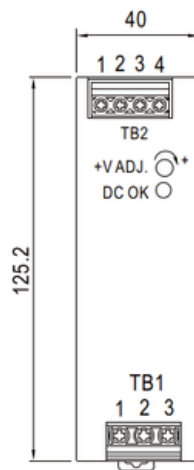

Front View

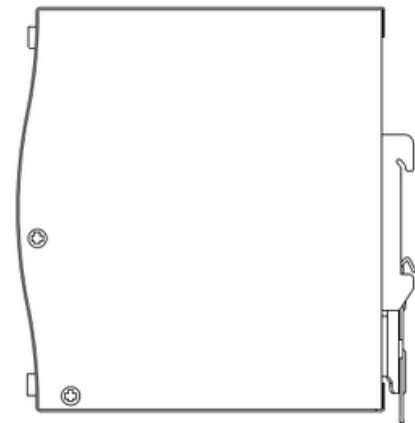

Side View

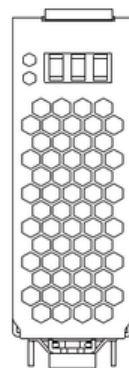

Bottom View

Terminal Pin No. Assignment (TB1)

Pin No.	Assignment
1	FG ⚡
2	AC/N or DC -
3	AC/L or DC +

Terminal Pin No. Assignment (TB2)

Pin No.	Assignment
1,2	DC OUTPUT -V
3,4	DC OUTPUT+V

SWITCHING POWER SUPPLY

120W Single Output Industrial DIN RAIL

Installation Instruction

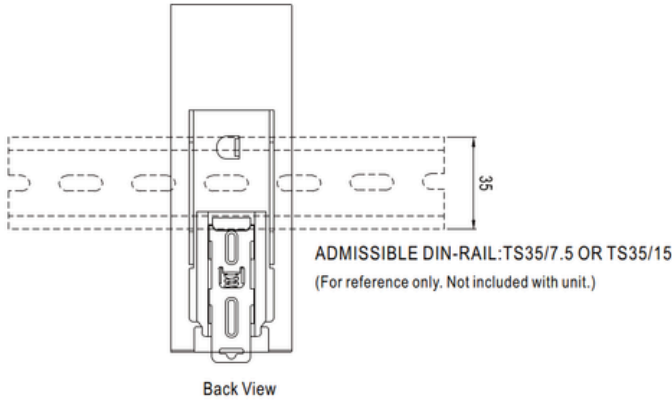

This series fits DIN rail TS35/7.5 or TS35/15.
For installation details, please refer to the Instruction manual.

Installation Manual

1. Always allow good ventilation clearances, 5mm left and right, 40mm above and 20mm below, around the unit in use to prevent it from overheating. Also a 10-15 cm clearance must be kept when the adjacent device is a heat source.
2. The appropriate mounting orientation for the unit is vertical, the input terminals at the bottom and output on the top. Mounting orientations other than that, such as upside down, horizontal, or table-top mounting, is not allowed.
3. Use copper wire only, and recommended wires are shown as below.

AWG	18	16	14	12
Rated Current of Equipment (Amp)	7A	10A	15A	20A
Cross-section of Lead(mm ²)	0.8	1.3	2.1	3.3

Note:
Current each wire carries should be de-rated to 80% of the current suggested above when using 5 or more wires connected to the unit.

Make sure that all strands of each stranded wire enter the terminal connection and the screw terminals are securely fixed to prevent poor contact. If the power supply possesses multi-output terminals, please make sure each contact is connected to wires to prevent too much current stress on a single contact.

SWITCHING POWER SUPPLY

120W Single Output Industrial DIN RAIL

4. Use wires that can withstand temperatures of at least 80°C, such as UL1007.
5. Recommended wire strapping length is 5mm (0.197").
6. Recommended screwdriver is 3mm, slotted type.
7. The recommended torque setting for terminals is shown as below.

Model	I/P	O/P
MIT-120	7.5 kgf-cm (6.5 Lb-in)	7.5 kgf-cm (6.5 Lb-in)
MIT-240	7.5 kgf-cm (6.5 Lb-in)	7.5 kgf-cm (6.5 Lb-in)
MIT-480	10.35 kgf-cm (9 Lb-in)	10.35 kgf-cm (9 Lb-in)

8. Suggested fuse and maximum number of the PSUs that can be connected to a circuit breaker at 230V are shown as below.

Model	Fuse	Circuit breaker C16	Circuit breaker D16
MIT-120	T4A/L250V	5	10
MIT-240	T5A/L250V	4	10
MIT-480	T8A/L250V	3	5

9. Mounting Instruction :Mount as shown in figure only, with input terminals down, or else sufficient cooling will not be possible.

Admissible DIN rail : TS35/7.5 or TS35/15

For rail fastening : 

- (a) Tilt the unit slightly rearwards.
- (b) Fit the unit over top hat rail.
- (c) Slide it downward until it hits the stop.
- (d) Press against the bottom for locking.
- (e) Shake the unit slightly to check the locking action.

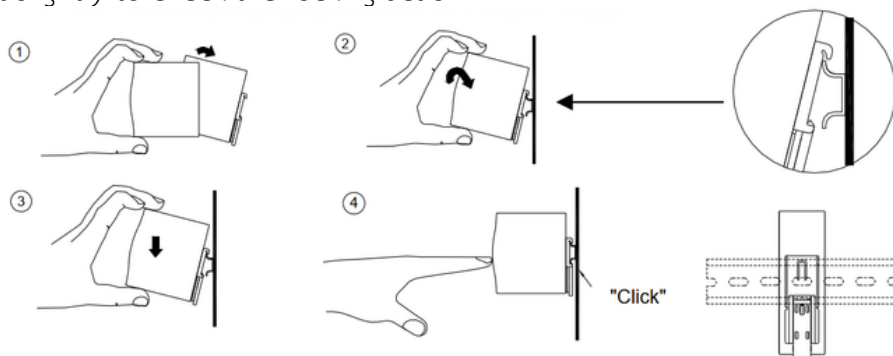

SWITCHING POWER SUPPLY

120W Single Output Industrial DIN RAIL

Warning / Caution !!

1. Risk of electrical shock and energy hazard. All failure should be examined by a qualified technician.
Please do not remove the case of the power supply by yourself!
2. Risk of electric arcs and electric shock (danger to life). Connecting both the primary and the secondary sides together is not allowed.
3. Risk of burn hazard. Do not touch the unit in operation and shortly after disconnection!
4. Risk of fire and short circuit. The openings should be protected from foreign objects or dripping liquids.
5. Only install the unit in a pollution degree 2 environment (Note.1).
6. Please do not install the unit in places with high moisture or near the water.
7. The maximum operating temperature is 50°C for MIT-120-24, MIT-240-24, MIT-480-24, please do not install the unit in places with high ambient temperature or near fire source.
8. The FG (\perp) must be connected to PE (Protective Earth).
9. Output current and output wattage must not exceed the rated value on its specification.
10. Disconnect system from supply voltage: Before commencing any installation, maintenance or modification work: Disconnect your system from supply voltage. Make sure that inadvertent connection in circuit will be impossible!
11. For continued protection against risk of fire, replace only with same type and rating of fuse. Pour ne pas compromettre la protection contre les risqué d'incendie, remplacer par un fusible de même type et de memes caractéristiques nominales.

Note.1: Pollution Degree 2 applies where there is only non-conductive pollution that might temporarily become conductive due to occasional condensation. Generally refer to dry, well-ventilated locations, such as control cabinets.



Thank you



Website



LINE Official

Website : www.mit-trade.com
Email : info.mittrade@gmail.com
Phone : 081-123-2475



081-123-2475



Line id: mitttrade



www.mit-trade.com



info.mittrade@gmail.com