

## TEMPERATURE CONTROLLER



## USER MANUAL FOR TCPK4 4 CHANNELS

## USER MANUAL FOR TCPK4 - 4 CHANNELS

### FEATURES:

- Multiple TC signal types for option, with DC 300V isolation between signal inputs, able to connect grounding probe
- With many functions, measured display, control output, RS485 communication, etc.
- Optional many types of PID arithmetic, and with auto-tuning function.
- Using for industrial machinery, machine tools, measuring instruments.
- With limiting target value setting function

The instruction explains VDAX series instrument settings, connections, name and etc., please read carefully before you use the temperature controller. Please keep it properly for necessary reference.

### I. Safe Caution

#### Warning

1. When the failure or abnormal of products lead to a system of major accidents, please set the proper protection circuit in the external.
2. Please don't plug in before completing all the wire. Otherwise, it may lead to electric shock, fire, fault.
3. Not allow to use outside the scope of product specification, otherwise it may lead to fire, fault.
4. Not allow to use in the place where is inflammable and explosive gas.
5. Do not touch power terminal and other high voltage part when the power on, otherwise you may get an electric-shock.
6. Do not remove, repair and modify this product, otherwise it may lead to electric shock, fire, fault.

#### Caution

1. The product should not be used in a nuclear facility and human life associated medical equipment.
2. The product may occur radio interference when it used at home. You should take adequate countermeasures.
3. The product gets an electric shock protection through reinforced Insulation. When the product is embedded in the devices and wiring, please subject to the specification of embedded devices.
4. In order to prevent surge occurs, when using this product in the place of over 30m indoor wiring and wiring in outdoor, you need to set the proper surge suppression circuitry.

5. The product is produced based on mounting on the disk. In order to avoid to touch the wire connectors, please take the necessary measures on the product.
6. Be sure to observe the precautions in this manual, otherwise there is a risk of a major injury or accident.
7. When wiring, please observe the local regulation.
8. To prevent to damage the machine and prevent to machine failure, the product is connected with power lines or large capacity input and output lines and other methods please install proper capacity fuse or other methods of protection circuit.
9. Please don't put metal and wire clastic mixed with this product, otherwise it may lead to electric shock, fire, fault.
10. Please tighten screw torque according to the rules. If not, it may lead to electric shock and fire.
11. In order not to interfere with this product to dissipate heat, please don't plug casing around the cooling vent hole and equipment.
12. Please don't connects any unused terminal.
13. Please do the cleaning after power off, and use the dry-cleaning cloth to wipe away the dirt. Please don't use desiccant, otherwise, it may cause the deformation or discoloration of the product.
14. Please don't knock or rub the panel with rigid thing.
15. The readers of this manual should have basic knowledge of electrical, control, computer and communications.
16. The illustrations, data examples and picture examples used in this manual are recorded for the convenience of understanding the manual, and are not guaranteed to be the results of the operation.
17. In order to use this product with safety for long-term, regular maintenance is necessary. The life of some parts of the equipment is by some restrictions, but the performance of some will change for using many years.
18. Without prior notice, the contents of this manual may will be change. We hope these is no any loopholes, if you have questions or objections, please contact us.

 Caution of Install & Connection

1. Installation:

1. This product is used in the following environmental standards. (IEC61010-1) [Overvoltage category, class of pollution 2].
2. This product is used in the following scope: environment, temperature, humidity and environmental conditions. Temperature:0~50°C; humidity:45~85%RH; Environment condition: Indoor warranty. The altitude is less than 2000m.

3. Please avoid using in the following places:

The place will be dew for changing temperature; with corrosive gases and flammable gas; with vibration and impact; with water, oil, chemicals, smoke and steam facilities with Dust, salt, metal powder; and with clutter interference, static electric and magnetic fields, noise; where has air conditioning or heating of air blowing directly to the site; where will be illuminated directly by sunlight; where accumulation of heat will happen caused by radiation.

4. On the occasion of the installation, please consider the following before installation.

In order to protect heat saturated, please ensure adequate ventilation space. Please consider connections and environment, and ensure that the products below for more than 50mm space. Please avoid to installed over the machine of the calorific value (Such as heaters, transformer, semiconductor operations, the bulk resistance). When the surrounding is more than 50°C, please using the force fan or cooling fans. But don't let cold air blowing directly to the product. In order to improve the anti-interference performance and security, please try to stay away from high pressure machines, power machines to install. Don't install on the same plate with high pressure machine and the product. The distance should be more than 200mm between the product and power line. The power machine shall be installed at a distance as far as possible.

2. Cable caution:

1. Please use specified compensation wire in the place of TC input; Please use insulated TC if the measured device is heated metal.
2. Please use the cable of lesser resistance in the place of RTD input, and the Cable (3 wire) must be no resistance difference, but the total length should be within 5m.
3. In order to avoid the effect of noise, please put the input signal away from meter cable, power cable, load cable to wiring.
4. In order to reduce the power cables and the load power cables on the effect of this product, please use noise filter in the place where easy to effect. You must install it on the grounding of the disk if you use the noise filter, and make the wiring to be shortest between noise filter output side and power connectors. Don't install fuse and switch on the wiring of Noice filter output side, otherwise it will reduce the effect of noise filter.

5. It takes 5s from input power to output. If there is a place with interlocking actions circuit signal, please use timer relay.
6. Please use twisted pair with a shield for analog output line, can also connect the common-mode coil to the front-end of the signal receiving device to suppress line interference, if necessary, to ensure the reliability of signal.
7. Please use twisted pair with a shield for remote RS485 communication cable, and deal with the shield on the host side earth, to ensure the reliability of signal.
8. This product don't has the fuse; please set according to rated voltage 250V, rated current 1A if you need; fuse type: relay fuse.
9. Please use suitable slotted screwdriver and wire. Terminal distance: 5.0mm. Screwdriver size: 0.6X3.5, length of slotted screwdriver >130mm. Recommended tightening torque: 0.5N.m. Proper cables: 0.25 ~ 1.65mm single cable/multiple core cable
10. Please don't put the crimp terminal or bare wire part contact with adjacent connector.

## II. Model Illustration

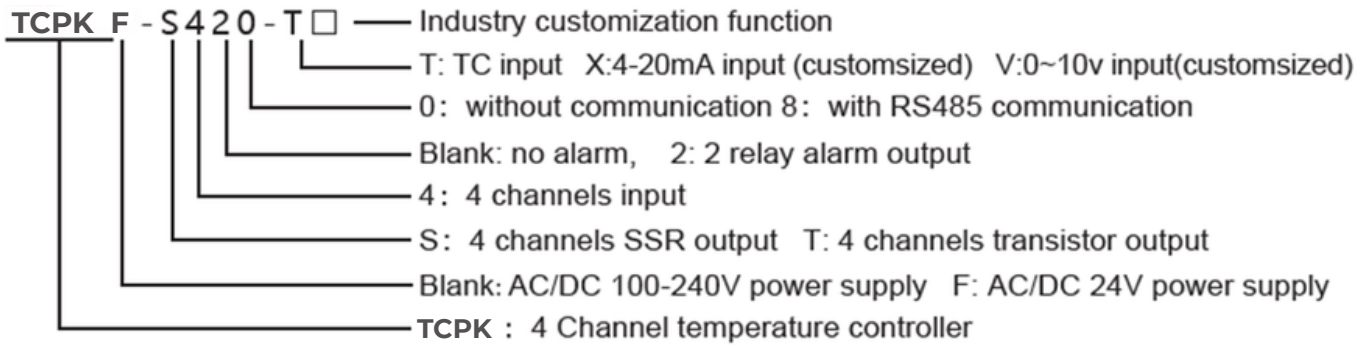

## III. Model Description

Model	Input	OUT1 ~ OUT4	AU1,AU2 Auxiliary alarm	RS485
TCPK-S428-T	TC	SSR output	Yes	Yes
TCPK-S420-T	TC	SSR output	Yes	NO
TCPK-T428-T	TC	Transistor output	Yes	Yes
TCPK-T420-T	TC	Transistor output	Yes	NO
TCPK-S48-T	TC	SSR output	NO	Yes
TCPK-S40-T	TC	SSR output	NO	NO
TCPK-T48-T	TC	Transistor output	NO	Yes
TCPK-T40-T	TC	Transistor output	NO	NO

#### IV. Specifications

##### 1. Electrical parameters:

Sample rate	1 times per second per channel
Power supply	AC/DC 100-240V (85-265V), AC/DC 24V power supply (customized, SSR voltage output requires DC 24V power supply)
Power consumption	< 10VA@220V 3W@DC 24V
Environment	Indoor use, Temperature: 0 ~ 50°C no condensation, Humidity: < 85%RH, altitude < 2000m
Storage environment	-10 ~ 60°C, no condensation
SSR output	DC 24V pulse level, load < 20mA
Transistor output capacity	@25 °C DC 24V maximum 100mA, current derating 8mA per 10 °C temperature rise, withstand voltage 100V
Communication port	RS485 port, Modbus-RTU protocol
Insulation impedance	Input, output, power cabinet > 20M $\Omega$
ESD	IEC/EN61000-4-2 Contact $\pm$ 4KV /Air $\pm$ 8KV perf.Criteria B
Pulse triap anti-interference	IEC/EN61000-4-4 $\pm$ 2KV perf.CriGTeria B
Surge immunity	IEC/EN61000-4-5 $\pm$ 2KV perf.CriGTeria B
Voltage drop & short interruption immunity	IEC/EN61000-4-29 0% ~ 70% perf.CriGTeria B
Dielectric strength	Signal input and output and power supply 1500VAC for 1 minute, below 60V between low voltage circuits AC 500V for 1 minute
Total weight	About 400g
Shell material	PA66-FR (Flame Class UL94V-0)
Panel material	PVC film and PEM silicone key
Power-off data protection	10 years, times of writing: 1 million times
Safety Standard	IEC61010-1 Overvoltage category II, pollution level 2, level II (Enhanced insulation)

## 2. Measurement signal parameter

Input Type		Symbol	Measurement Range	Resolution	Accuracy	Input Impedance /Auxiliary current	Communication Code
K	K1		-50~1200	1°C	0.5%F.S. ±3 digits	>1MΩ	0
	K2		-50.0~999.9	0.2°C	0.5%F.S. ±1°C	>1MΩ	16
J	J1		0~1200	1°C	0.5%F.S. ±3 digits	>1MΩ	1
	J2		0.0~999.9	0.2°C	0.5%F.S. ±1°C	>1MΩ	17
E	E1		0~850	1°C	0.5%F.S. ±3 digits	>1MΩ	2
	E2		0.0~850.0	0.3°C	0.5%F.S. ±1°C	>1MΩ	18
T	T1		-50~400	1°C	0.5%F.S. ±3°C	>1MΩ	3
	T2		-50.0~400.0	0.4°C	0.5%F.S. ±3°C	>1MΩ	19
B			250~1800	1°C	1%F.S. ±2°C	>1MΩ	4
R			-10~1700	1°C	1%F.S. ±2°C	>1MΩ	5
S			-10~1600	1°C	1%F.S. ±2°C	>1MΩ	6
N	N1		-50~1200	1°C	0.5%F.S. ±1°C	>1MΩ	7
	N2		-50.0~999.9	0.2°C	0.5%F.S. ±1°C	>1MΩ	20
0~50mV			-1999~9999	12bit	0.5%F.S. ±3 digits	>1MΩ	12

## 3. Isolation diagram

AC/DC 100-240V power supply isolation diagram

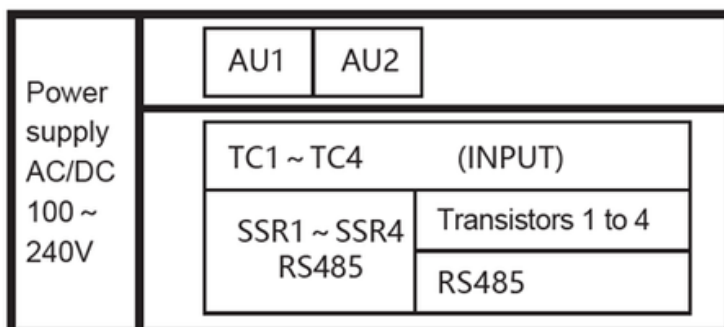

————— :Basic isolation AC 1500V

————— :Functional isolation AC 500V

AC/DC 24V power supply isolation diagram

Power supply 24VDC  SSR1 ~ SSR4	AU1	AU2
	TC1 ~ TC4 (INPUT)	
	Transistors 1 to 4	
	RS485	

V. Dimensions and Installation method

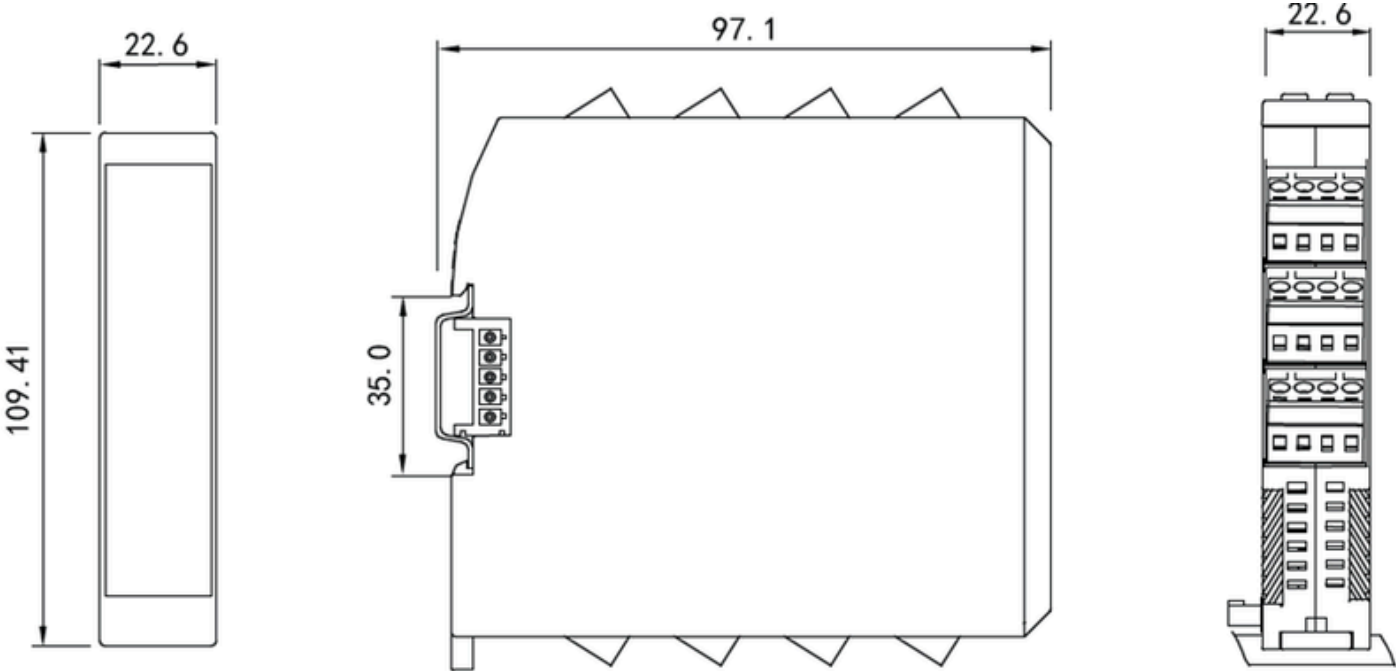

## VI. Connection Diagram

### 1. Wiring diagram description

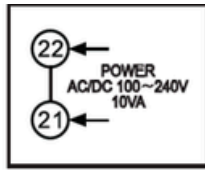

AC/DC 100~240V power supply

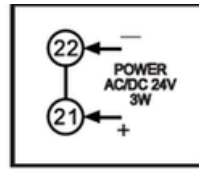

AC/DC 24V power supply

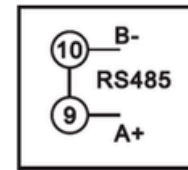

RS485 communication interface

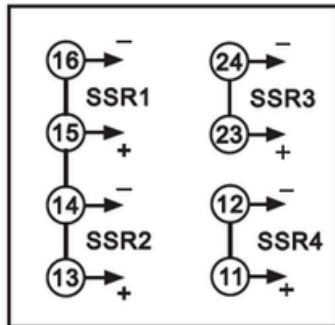

SSR output

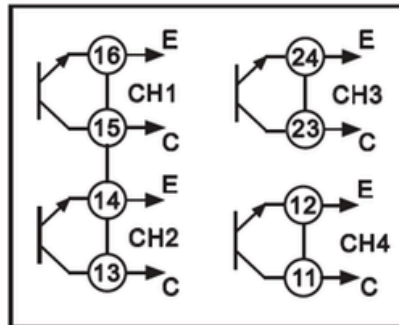

Transistor output

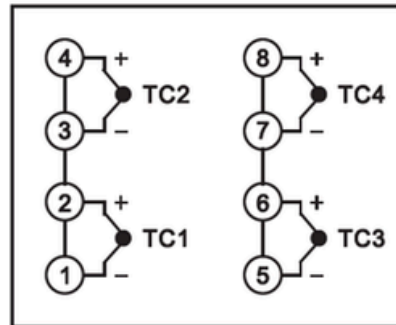

TC thermocouple input

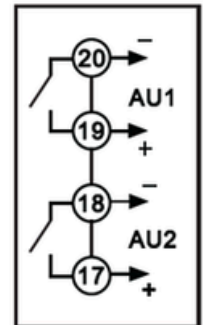

AU1,AU2 output

### 2. Examples of partial wiring diagram

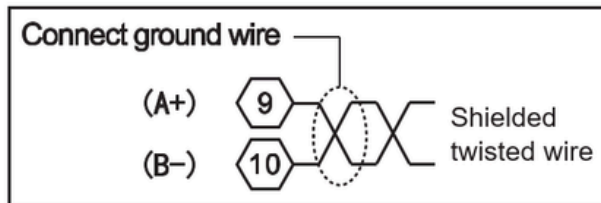

RS485 communication wiring diagram description

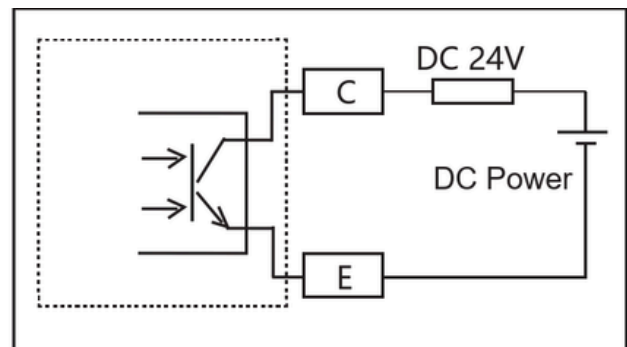

Transistor output wiring diagram description

In case of any change, please subject to the wiring diagram on the actual product.

### VII. Name of universal panel

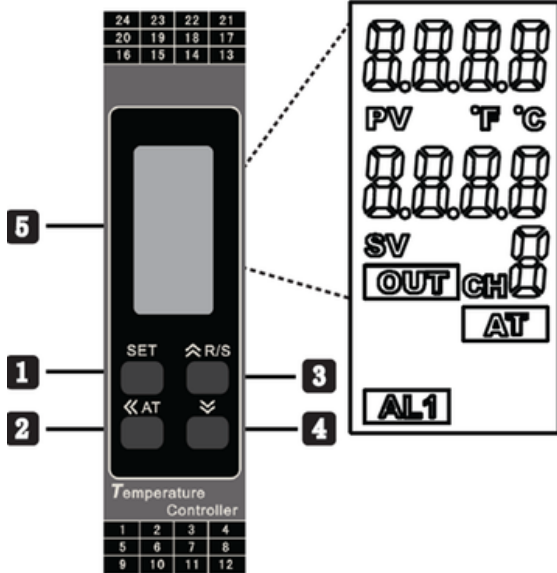

No.	Symbol	Name	Function Description
1	SET	SET Function key	Menu key /Confirm key for entering or exiting parameter modification mode, or confirm to save the modified parameters and switch channels.
2	⏪	Shift/AT Key	Activation key /Shift key /AT auto-tuning key, long press in measurement control mode to enter or exit auto-tuning key.
3	⏩	Add key/R/S	Add key/menu up key, in measurement control mode, long press can realize RUN /STOP Mode switch
4	⏴	Decrease	Decrease key/ Next Menu key

No.	Symbol	Name	Function Description
5	<b>PV</b>	PV	Measurement value, display measurement value or menu symbol
	<b>SV</b>	SV	Set value, display set value or menu parameter
	<b>CH</b>	CH	Channel indication window
	<b>OUT</b>	OUT	OUT indication, when there is display, it indicates the current channel control is ON, when there is no display, it indicates that the current channel control is OFF
	<b>AT</b>	AT	AT instruction. When there is a display, it indicates that the current channel is performing auto-tuning. When there is no display, it indicates that there is no auto-tuning or auto-tuning is complete.
	<b>T °C</b>	°C°F	Temperature unit symbol
	<b>AL1</b>	AL1	The first alarm output indicates that if there is a display output, it is ON, and if there is no display output, it is OFF

VIII. Operation Process and Menu Illustration

1.Operation process & method

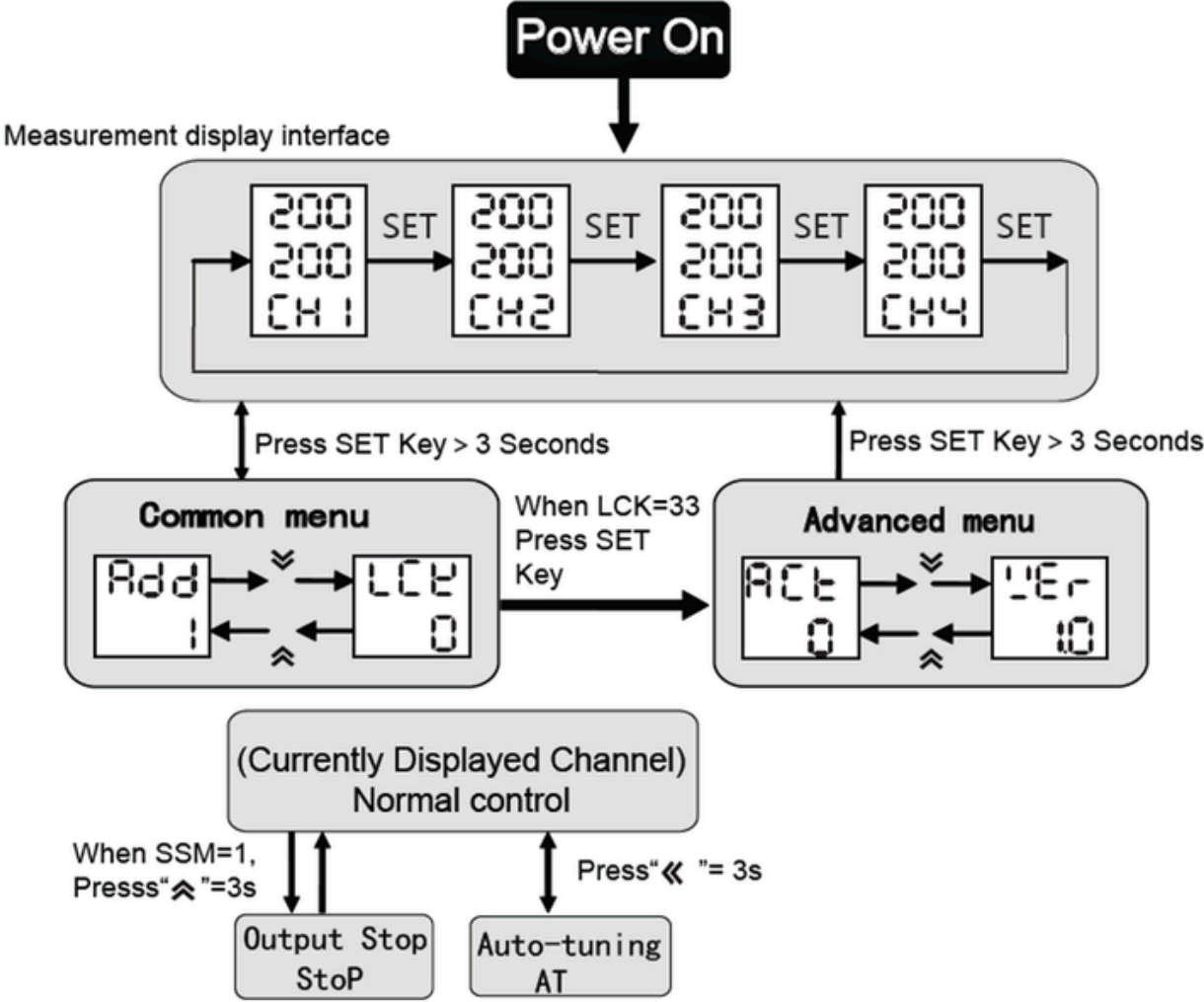

2.Channel switching operation

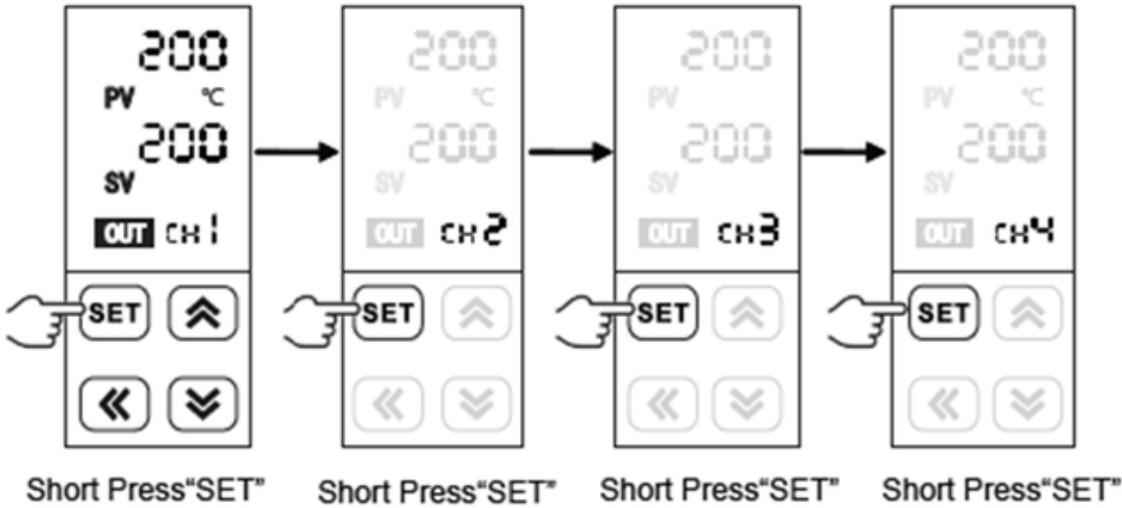

### 3.Parameter modification operation

#### 3.1. Common menu settings

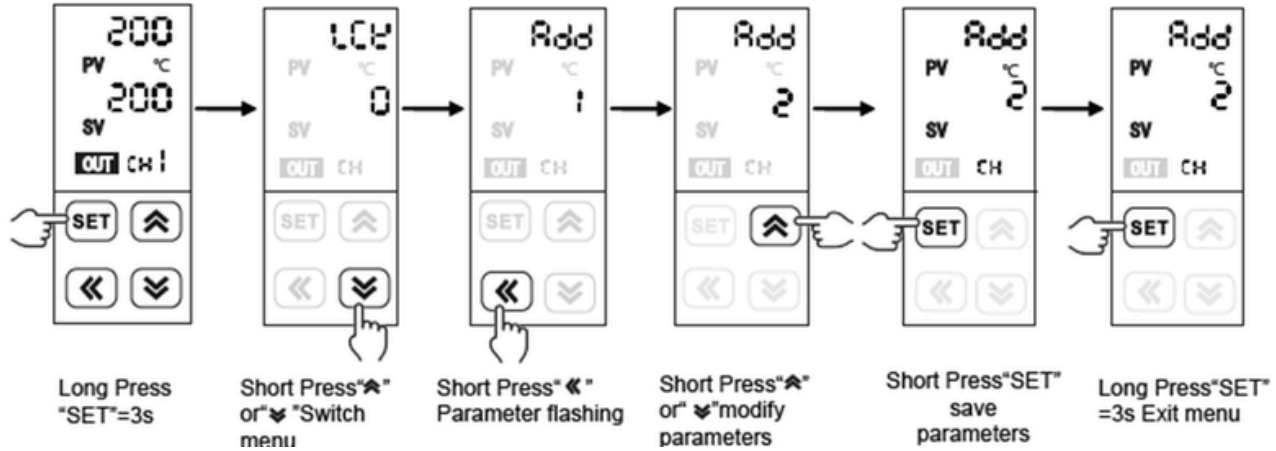



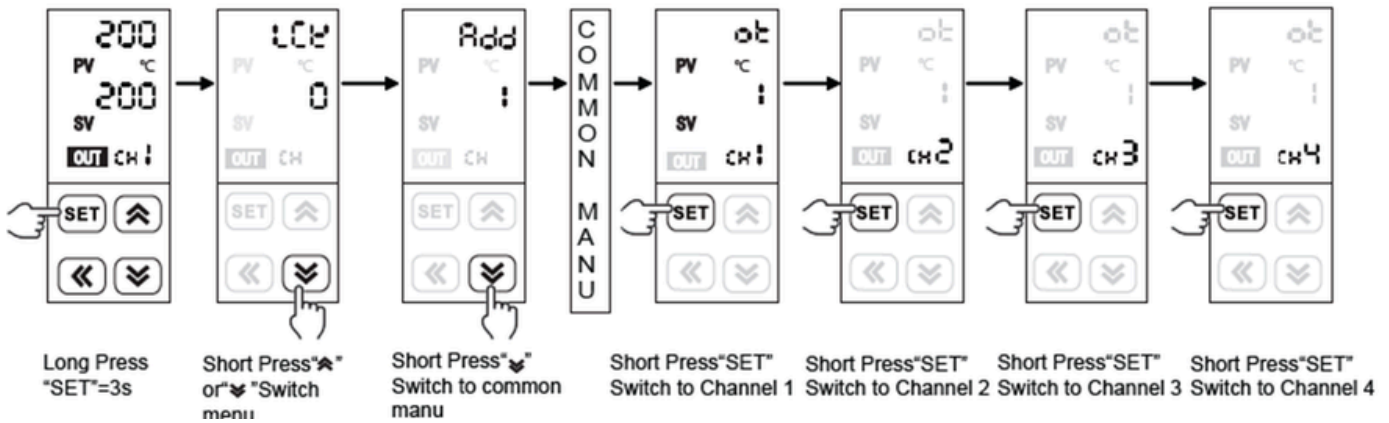

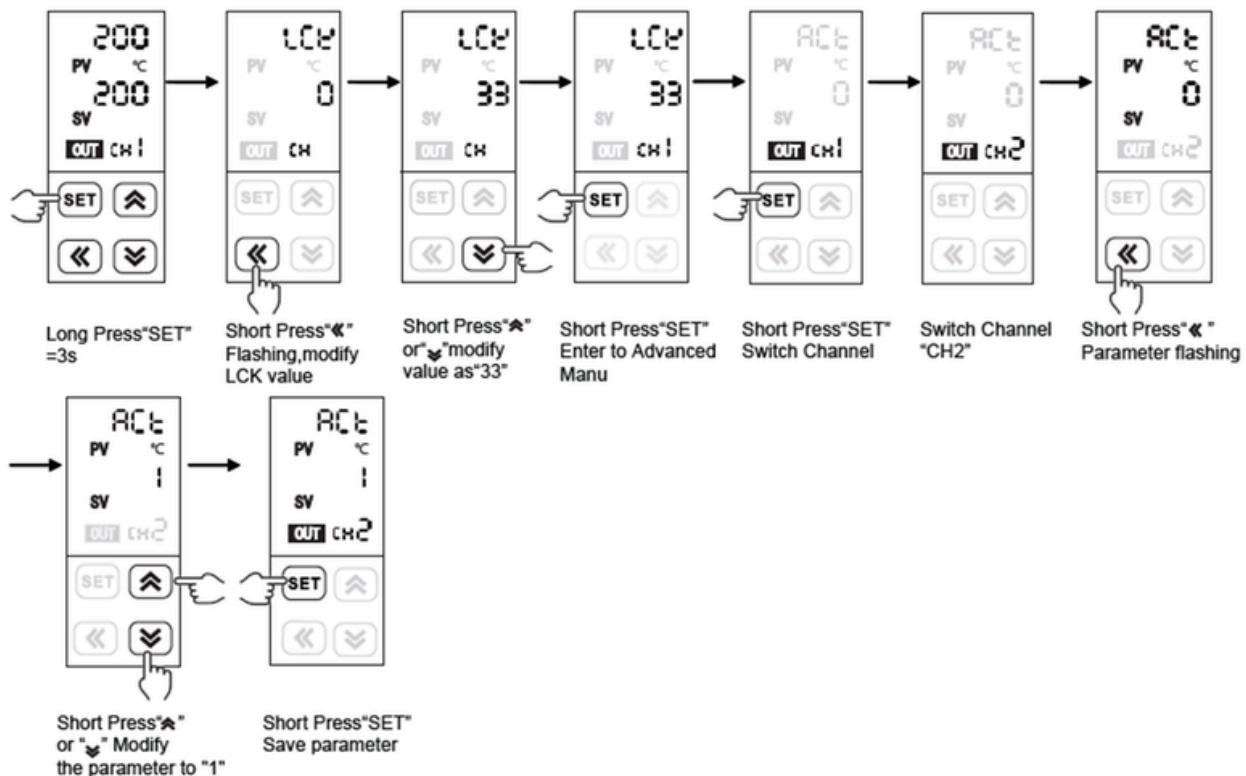

#### 3.2 Setting menu parameters for different channels operation



#### 3.3 Set advanced menu parameters operation





- a. In normal measurement control mode after power on, press and hold the “SET” key for more than 3 seconds to enter the menu parameter viewing mode, short press “SET” key to switch the display channel, the channel number is displayed in the CH indication window, and the panel display correspond to the channel number;
- b. In the menu view mode, short press “” or “” key check the common menu parameters circularly.
- c. In the menu view mode, short press the “” key to flash the viewed menu parameter value to enter the parameter modification mode, and each short press can move one bit to the left; this cycle.
- d. In the parameter modification mode, press the “” or “” key once to increase or decrease the flashing data bit by one.
- e. In the parameter modification mode, shortly press the "SET" key after the parameter is modified to save the modified parameter and long press “SET” exit to the menu view mode.
- f. In normal measurement control mode, press and hold the “” key for more than 3 seconds to enter the PID auto-tuning state corresponding to the channel.
- h. In the normal measurement control mode, press and hold the “” key for more than 3 seconds to enter or exit the running or stop mode corresponding to the channel; the stop mode SV window displays "STOP".

Note that the SSM should enable panel operation. "STOP" is displayed.

### 1. Common Menu Illustration

 Hide parameters according to model

No.	Symbol	Name	Illustration	Setting range	Factory setting
1		PV	Measuring display value, it will flash or display LLLL/HHHH when the value overflow measure range. Unit: °C°F or no unit	Refer to measured signal table	
2		SV	Control item setting value, Unit: °C°F or no unit	SLL~SLH	
3		CH	Channel number display window	1 ~ F	
4		LCK	Lock function; 0001: SV value cannot be changed; 0010: menu setting value can be read only; 0033: advanced menu can be accessed; 0123: menu restore factory setting	0 ~ 9999	0
5		ADD	Communication address	1 ~ 247	1
6		BAD	RS485 communication baud rate 4.8 (0) : 4800 ; 9.6(1) : 9600 ; 19.2 (2) : 19200 ; 38.4(3) : 38400	0 ~ 3	1

No.	Symbol	Name	Illustration	Setting range	Factory setting
7	P-ty	PRTY	Communication parity check setting 0: NO 1: ODD 2: EVEN	0 ~ 2	0
8	dAtC	DATC	Communication data transport sequence 000; 1st bit function reserved; 2nd bit is byte sequence exchange; 3rd bit function reserved.	Refer to COM protocol note ③	0
9	AL1	AL1	The first alarm value, Note: When used as a deviation value, setting it as a negative number will be treated as an absolute value	FL ~ FH	5
10	HY1	HY1	The first alarm hysteresis	0 ~1000	1
11	Ad1	AD1	The first alarm method, please refer to the communication protocol alarm parameters and output logic diagram for details	0 ~ 6	3
12	ot	OT	Contral mode, 0: ON/OFF heating control,1: PID heating control, 2: ON/OFF cooling control 3: Reversed, 4: Over temperature cooling output 5: PID cooling	0 ~ 5	1
13	P	P	Proportional band, the smaller the value is, the faster the system responds, otherwise, it is slower. When P=0, no PID control, unit same as PV	0 ~ 9999	30
14	I	I	Integral time, the smaller the value is, the stronger the integral action is, otherwise,it is weaker. When I=0, no integral action, unit: s.	0 ~ 9999	120
15	d	D	Differential time: reduce the differential action to an appropriate value to prevent system oscillation.The larger the value, the stronger the differential action. Unit: second	0 ~ 9999	30
16	A-M	A-M	Auto-manual control switch, AUTO (0): auto control only; MAN (1): manual control only;	AUTO~AM	AUTO
17	CP	CP	OUT1 control cycle, 1: SSR control output, 4-200: relay control output. Unit: s	1 ~ 200	1

No.	Symbol	Name	Illustration	Setting range	Factory setting
18	db	DB	ON/OFF control hysteresis (positive and negative numbers work the same); when OT=3, it is the dead zone for cooling control (positive and negative numbers work differently); after change the INP setting, please change this parameter according to the decimal point position.	0 ~ 1000	5
19	InP	INP	Optional input signal, refer to input signal parameters table. Note: after selecting the signal, pls set corresponding parameters	Refer to measured signal specification	K1
20	PS	PS	Amend value, display value= actual measured value + amend value	-1000 ~1000	0

## 2.Advanced Menu

No.	Symbol	Name	Illustration	Setting range	Factory setting
21	ACT	ACT	Control execution mode, 0~1: SSR output control or transistor output	0 ~ 1	0
22	AE1	AE1	The first alarm extension function, please refer to the communication protocol alarm extension function table for details	0 ~ 5	0
23	dP	DP	Decimal point setting is effective under the linear signal input	0 ~ 3	0
24	dtr	DTR	PV fuzzy tracking value, properly set this value on some occasions, it can get a more stable control display value, this value is unrelated with actual measured value. Note: after setting this value, when alarm setting value is equal to SV setting value, alarm output operation is subject to actual measured value. Set as 0 to close this function. The temperature input unit: Fahrenheit or Celsius. The linear signal input unit: Engineering Digits	0.0 ~ 2.0 0 ~ 20	1.0

No.	Symbol	Name	Illustration	Setting range	Factory setting
25	SSA	SSM	Press the key on the panel to switch the RUN / STOP, 0: prohibited, 1: Open This setting is only related to panel operation, not related with communication	0 ~ 1	0
26	SLL	SLL	Lower limit of the target SV range. Over this limit, SV can't be modified	FL ~ FH	
27	SLH	SLH	High limit of the target SV range. Over this limit, SV can't be modified	FL ~ FH	
28	FL	FL	Measure range low limit, the setting value must be smaller than measure range high limit.	Refer to measured signal parameter table	
29	FH	FH	Measure range high limit, the setting value must be more than measure range low limit.		
30	Ft	FT	Filter coefficient of each channel, the larger the value, the stronger the filtering effect.	0 ~ 255	10
31	Pt	PT	Compressor start delay time, unit: s	0 ~ 9999	0
32	PdC	PDC	PID type selection 0 (FUZ): Advanced fuzzy PID algorithm; 1(STD): Ordinary PID algorithm; 2(FUZ1): Advanced fuzzy PID precise tuning algorithm	FUZ ~ FUZ1	FUZ
33	Unit	UNIT	Temperature unit setting °C: Celsius °F: Fahrenheit,note: this unit setting is only for temperature measurement signals	(25)°C (26)°F	(25)°C
34	P-S	PRS	Setting parameter reserve position:0 (EEP): EEPROM with power failure protection; 1(RAM): RAM without power failure protection. Description of setting parameter storage address: EEP and RAM. EEP means that the setting parameters are written into EEPROM and can be permanently saved after power failure. It is generally used for factory setting parameters of equipment. Because EEPROM has the limit of writing times, too many and too frequent writes will be damaged; RAM: it means that the parameters are stored in RAM without writing limit and will not be damaged due to frequent writing. The parameters setting will not be saved when the equipment is powered off.	EEP/RAM	EEP

No.	Symbol	Name	Illustration	Setting range	Factory setting
			After power on, they will be restored to the parameters saved in EEPROM by the equipment manufacturer. It is usually used for parameters frequent writing when communicating with the upper computer PLC. The method of using this parameter is to set this parameter as EEP firstly. After the equipment factory has finished debugging the equipment and set the parameters, the parameters are saved in EEPROM, and then PRS is modified into RAM, and the equipment is delivered to the user for use, so as to prevent erroneous modification or long-term communication writing data from damaging EEPROM.		
35	RSS	RSS	RUN/STOP reserve position: 0 (EEP): EEPROM with power failure protection; 1 (RAM): RAM without power failure protection. this parameter using method: if the meter is required to be in stop mode every time when it is powered on, first set RSS to EEP, and then set "start stop operation" = STOP. This setting parameter will be saved for a long time; Then set RSS to RAM. When using, the upper computer starts/stops the instrument, which is stored in RAM. After power on again, the instrument still enters STOP mode.	EEP/RAM	EEP
36	AU1P	AU1P	Auxiliary output 1 programming is used to program the AU1 output function. If equipped, it is effective. Please refer to the auxiliary output function mapping table for details.	0 ~ 5	1
37	AU2P	AU2P	Auxiliary output 2 programming is used to program the AU2 output function. If equipped, it is effective. Please refer to the auxiliary output function mapping table for details.	0 ~ 5	2
38	DN	DN	Display the number of channels, indicating the number of measurement channels actually used by the instrument	1 ~ 4	4
39	DNS	DNS	Display the starting channel number, which is used to indicate number of channels 1 in multi-machine application. For example: when DNS=3, CH3~CH6 represent 1~4 channels respectively	1 ~ 12	1

No.	Symbol	Name	Illustration	Setting range	Factory setting
40	dnt	DNT	Channel cycle display time, 0 means cancel automatic cycle display, unit: s	0 ~ 99	4
41	blt	BLT	Backlight delay setting: When set to 0, the backlight stays on, otherwise it will turn off after a delay. Unit: Division	0 ~ 10	5
42	ver	VER	Software version.	--	--

Alarm parameter and output logic diagram

Explanation of symbols: "☆" means HY, "▲" means alarm value, and "△" means SV value

Alarm code	Alarm form	Alarm output action (AL11~AL14) Figure: The shaded area means the alarm
1	High limit alarm of absolute value	
2	Low limit alarm of absolute value	
3	※High limit alarm of deviation	
4	※Low limit alarm of deviation	
5	※Alarm outside upper /lower limit deviation	
6	※Alarm within upper /lower limit deviation	

※ When the alarm value with deviation alarm is set to a negative number, it is treated as an absolute value.





Alarm extension function table

	AE11~AE14 Value	Alarm handling method when it displays HHHH/LLLL	Remark
Power on, no alarm inhibition	0	Alarm status remains the state before displays HHHH/LLLL	As long as the alarm condition is met, alarm output immediately
	1	Alarm forced output	
	2	Alarm forced close	
Power on, alarm inhibition	3	Alarm status remains the state before displays HHHH/LLLL	After power on and before the PV value reaches the SV for the first time, the alarm will not output. After that alarm work normally
	4	Alarm forced output	
	5	Alarm forced close	

Auxiliary Output Function Mapping Table

Code	Function	Function Description
0	DO	AUX is used for DO output, communication writing 0 or 1 is executed to turn off or turn on
1	CH1-AL1	CH1 Alarm output
2	CH2-AL1	CH2 Alarm output
3	CH3-AL1	CH3 Alarm output
4	CH4-AL1	CH4 Alarm output
5	ALL-AL1	CH1-CH4 simultaneously alarm output

## IX. Key function operation

1. Monitoring mode operation (RUN/STOP):
  1. SSM is set in open panel operation; Otherwise, the settings only be modified during communication.
  2. Under the measure mode, long press “” key to enter the STOP mode, SV window will display “STOP”, main control output will stop or keep the minimum output.
  3. Under STOP mode, long press “” key to exit STOP mode, press “” key to modify SV value.
  4. Under STOP mode, alarm output and analog output work normally.
2. PID auto-tune operation:
  1. Before auto-tune procedure, please switch off the control output load power, or set the meter as STOP mode.
  2. Before auto-tune procedure, PV value should meet below condition: when it is PID heating control, PV needs to be much smaller than SV; when it is PID cooling control, PV needs to be much larger than SV.
  3. Before auto-tune procedure, please set a proper alarm value or eliminate the alarm condition, in order to prevent the auto-tune procedure from being affected by alarm output.
  4. Set the PID type and SV value; the factory default setting is fuzzy PID.
  5. Set as PID control, if there is OLL & OLH output limiting, please set the output to a proper range; factory default setting is OLL=0%, OLH=100%.
  6. Exit STOP mode, or switch on the load Power, immediately long press “” key to enter auto-tune mode, then the AT indicator light is on.
  7. The auto-tune procedure will take some time, in order not to affect auto-tune result, please don't modify the parameters or power-off.
  8. When AT light goes out, it automatically exits auto-tune mode, PID parameters will be updated automatically, and then the meter will control automatically and exactly.
  9. During the auto-tune procedure, below actions will cause the termination of the process, long press “” key, measure beyond the scope, abnormal display, switch to STOP mode, power-off, etc.
  10. Note: In the occasions with output limiting operation, sometimes, even if the auto-tune is carried out, the best PID parameters still cannot be obtained.
  11. Experienced users can set a proper PID parameter according to their experience.

## X. Methods of simple fault

Display info	Method
LLLL/HHHH	Check whether the input is disconnected; check the FH value and FL value; determine whether the working environment temperature is normal; check whether the input signal selection is correct.

## XI. Communication protocol

The device uses Modbus RTU communication protocol for RS485 half-duplex communication, read function number 0x03, write function number 0x10 or 0x06, adopt 16-bit CRC check, the device does not return check error.

Data frame format:

Start bit	Data bit	Stop bit	Check bit
1	8	1	Settings in the PRTY menu

Communication abnormal Handling:

For abnormal response, set the highest bit of the function number to 1. For example: if the function number requested by the master is 0x03, the corresponding item of the function number returned by the slave is 0x83.

Error type code:

0x01 --- Illegal function: The function number sent by the host is not supported by the device.

0x02 --- Illegal address: The register address specified by the host exceeds the allowable range of the device address.

0x03 --- Illegal value: The value of the write data sent by the host exceeds the allowable range of the device.

Communication cycle:

The communication cycle refers to the time from the completion of the master data request to the completion of the slave return data. That is: communication cycle = request data sending time + slave device reply time + response delay time + response return time. Take the 9600 baud rate as an example: the single measurement data communication period is not less than 250ms.

### 1. Read the register

Example: The host reads the integer SV1 (SV= 200)

The address code of SV1 is 0x200C, the register number is 48205, because SV1 is an integer (2 bytes) and occupies 1 data register. The memory code for decimal integer 200 is 0x00C8

Host request (read multiple registers)							
1	2	3	4	5	6	7	8
Device Address	Function code	High start address	Low start address	Data byte length high bit	Data byte length low bit	※CRC code Low bit	※CRC code High bit
0x01	0x03	0x20	0x0C	0x00	0x01	0x4F	0xC9

Slave normal response (read multiple registers)						
1	2	3	4	5	6	7
Device Address	Function code	Quantity of data bytes	Data high bit	Data low bit	✘CRC code low bit	✘CRC code high bit
0x01	0x03	0x02	0x01	0xF4	0xB9	0xD2

Function number abnormal response: (e.g. host request address 0x2510)

Slave abnormal response (read multiple registers)				
1	2	3	4	5
Device Address	Function code	Error code	✘CRC code low bit	✘CRC code high bit
0x01	0x83	0x02	0xC0	0xF1

## 2. Write the register

For example: Host writes integer SV1 (SV=200)

The ADD code of SV1 is 0x200C, the register number is 48205, because SV is integer (2 byte), seizes 1 data register. The memory code of decimal integer 200 is 0x00C8

Host request (write multi-register)										
1	2	3	4	5	6	7	8	9	10	11
Meter ADD	Function code	Start ADD High bit	Start ADD Low bit	Data byte Length high bit	Data byte Length low bit	Data byte Length	Data high bit	Data low bit	✘CRC code low bit	✘CRC code high bit
0x01	0x10	0x20	0x0C	0x00	0x01	0x02	0x00	0xC8	0x86	0xC8

Slave normal answer (write multi-register)							
1	2	3	4	5	6	7	8
Meter ADD	Function code	Start ADD High bit	Start ADD Low bit	Data byte Length high bit	Data byte Length low bit	✘CRC code low bit	✘CRC code high bit
0x01	0x10	0x20	0x0C	0x00	0x01	0xCA	0x0A

Host write single-register SV (SV= 200)

Host request (write single-register)							
1	2	3	4	5	6	7	8
Meter ADD	Function code	ADD High bit	ADD Low bit	Data high bit	Data low bit	✳CRC code low bit	✳CRC code high bit
0x01	0x06	0x20	0x0C	0x00	0xCB8	0x43	0x9F

Slave normal answer (write single-register)							
1	2	3	4	5	6	7	8
Meter ADD	Function code	ADD High bit	ADD Low bit	Data high bit	Data low bit	✳CRC code low bit	✳CRC code high bit
0x01	0x06	0x20	0x0C	0x01	0xCB8	0x43	0x9F

Data address error response: (For example: Host request the Address index is 0x2510)

Slave abnormal response (write multiple registers)					
1	2	3	5	6	
Device Address	Function code	Error code	✳CRC code low bit	✳CRC code high bit	
0x01	0x90	0x03	0x0C	0x01	

Parameter address mapping table

No	Address (register number ①)	Parameter name	Parameter Description	Register Quantity	Read Write	Remark
1	0x2000~0x2003(48193~48196)	PV1~PV4	Measure value	1	R	
2	0x2004~0x2007(48197~48200)	STA1~STA4	Status value	1	R	②
3	0x2008~0x200B(48201~48204)	MV1~MV4	PID Output value	1	R/W	
4	0x200C~0x200F(48205~48208)	SV1~SV4	Setting Value	1	R/W	
5	0x2010~0x2013(48209~48212)	RSA1~RSA4	Power switch	1	R/W	④
6	0x2014~0x2017(48213~48216)	SSM1~SSM4	Panel R/S switch	1	R/W	
7	0x2018~0x201B(48217~48220)	SLL1~SLL4	Setting value low limit	1	R/W	
8	0x201C~0x201F(48221~48224)	SLH1~SLH4	Setting value high limit	1	R/W	

Reserve						
No	Address (register number ①)	Parameter name	Parameter Description	Register Quantity	Read Write	Remark
9	0x2100~0x2103(48449~48452)	INP1~INP4	Input type	1	R/W	
10	0x2104~0x2107(48453~48456)	FL1~FL4	Display low limit	1	R/W	
11	0x2108~0x210B(48457~48460)	FH1~FH4	Display high limit	1	R/W	
12	0x210C~0x210F(48461~48464)	DP1~DP4	Decimal point	1	R/W	
13	0x2110~0x2113(48465~48468)	PS1~PS4	Translation correction value	1	R/W	
14	0x2114~0x2117(48469~48472)	FT1~FT4	Display filter coefficient	1	R/W	
15	0x2118~0x211B(48473~48476)	DTR1~DTR4	Dispaly tracking value	1	R/W	
Reserve						
16	0x212C~0x212F(48493~48496)	UNIT1~UNIT4	Display Unit	1	R/W	
17	0x2130~0x2133(48497~48500)	PRS1~PRS4	Paramters saving address	1	R/W	
18	0x2134~0x2137(48501~48504)	RSS1~RSS4	RUN/STOP saving address	1	R/W	
19	0x2138(48505)	DN	Display channel quantity	1	R/W	
20	0x2139(48506)	DNS	Display starting channel number	1	R/W	
21	0x213A(48507)	DNT	Channel cycle display time	1	R/W	
22	0x213B(48508)	BLT	Backlight delay time	1	R/W	
Reserve						
23	0x2200~0x2203 (48705~48708)	AL11~AL14	Alarm value	1	R/W	
24	0x2204~0x2207 (48709~48712)	AD11~AD14	Alarm mode	1	R/W	
25	0x2208~0x220B (48713~48716)	HY11~HY14	Alarm hysteresis	1	R/W	
26	0x220C~0x220F (48717~48720)	AE11~AE14	Alarm extended mode	1	R/W	
27	0x2240 (48769)	AU1P	Auxiliary output 1 programming	1	R/W	

No	Address (register number ①)	Parameter name	Parameter Description	Register Quantity	Read Write	Remark
28	0x2241 (48770)	AU2P	Auxiliary output 2 programming	1	R/W	
29	0x2250 (48785)	AU1DO	DO output 1	1	R/W	
30	0x2251 (48786)	AU2D2	DO output 2	1	R/W	
Reserve						
31	0x2300~0x2303 (48961~48964)	OT1~OT4	Control Mode	1	R/W	
32	0x2304~0x2307 (48965~48968)	P1~P4	Proportional band	1	R/W	
33	0x2308~0x230B (48969~48972)	I1~I4	Integration time	1	R/W	
34	0x230C~0x230F (48973~48976)	D1~D4	Differential time	1	R/W	
35	0x2310~0x2313 (48977~48980)	CP1~CP4	Control period	1	R/W	
36	0x2314~0x2317 (48981~48984)	DB1~DB2	Data bit control hysteresis	1	R/W	
37	0x2318~0x231B (48985~48988)	AM1~AM4	Auto-Manual switch	1	R/W	
Reserve						
38	0x2324~0x2327 (48997~49000)	ACT1~ACT4	Output type	1	R/W	
39	0x2328~0x232B (49001~49004)	PT1~PT4	Cooling start delay	1	R/W	
40	0x232C~0x232F (49005~49008)	PDC1~PDC4	PID Type	1	R/W	
Reserve						
41	0x2500 (49473)	ADD	Communication Add	1	R/W	
42	0x2501 (49474)	BAD	Communication baud	1	R	
43	0x2502 (49475)	PRTY	Check bit selection	1	R	
44	0x2503 (49476)	DATC	Data transmission sequence	1	R	③
45	0x2504 (49477)	LCK	Password	1	R	
46	0x2505 (49478)	NAME	Meter Name	1	R	

Note①: The register number is the address converted to decimal plus 1 and then the register identification code 4 is added in front; for example: the register number of the data address 0x2000 is 8192 + 1 = 8193 and then 4 is added in front, that is, the register number 48193; Related applications can be seen, such as Siemens S7-200 PLC.

Note②: Channel status indication. When the data bit is 1, it means execution, and when it is 0, it means not executed.

D7	D6	D5	D4	D3	D2	D1	D0
----	HHHH	LLLL	----	----	----	AL1	OUT1

Note③: DATC communication data transmission sequence and response delay description

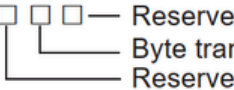
DATC:  Reserve  
 Byte transfer order: when it is 0, 1, 2, and when it is 1, 2, 1  
 Reserve

※ 16-bit CRC check code to get C program

```

unsigned int Get_CRC(uchar *pBuf, uchar num)
{
    unsigned int i,j;
    unsigned int wCrc = 0xFFFF;
    for(i=0; i<num; i++)
    {
        wCrc ^= (unsigned int)(pBuf[i]);
        for(j=0; j<8; j++)
        {
            if(wCrc & 1){wCrc >>= 1; wCrc ^= 0xA001;}
            else
                wCrc >>= 1;
        }
    }
    return wCrc;
}

```

④ : 0: Run 1: Stop 2: auto tuning 3: Stop auto tuning

Thank you for using  
TEMPERATURE CONTROLLER  
TCPK4 - 4 CHANNELS



Website



LINE Official

Website : [www.mit-trade.com](http://www.mit-trade.com)  
Email : [info.mittrade@gmail.com](mailto:info.mittrade@gmail.com)  
Phone : 081-123-2475

**PARKARN INSTRUMENT CO.,LTD**