

TEMPERATURE CONTROLLER



**USER MANUAL FOR TCPK16
16 CHANNELS**

USER MANUAL FOR TCPK16 - 16 CHANNELS

FEATURES:

- Multiple thermocouple signal types for option, weak isolation between signal inputs, able to connect grounding probe.
- With many functions, measured display, control output, RS485 communication, etc.
- Multi PID algorithm for option, with auto-tuning function.
- With power uniform distribution function for multi-channel loads.
- Suitable for industrial machinery, machine tools, measuring instruments.

The instruction explains instrument settings, connections, name and etc, please read carefully before you use the temperature controller. Please keep it properly for necessary reference.

I. Safe Caution

Warning

1. When the failure or abnormal of products lead to a system of major accidents, please set the proper protection circuit in the external.
2. Please don't plug in before completing all the wire. Otherwise, it may lead to electric shock, fire, fault.
3. Not allow to use outside the scope of product specification, otherwise it may lead to fire, fault.
4. Not allow to use in the place where is inflammable and explosive gas.
5. Do not touch power terminal and other high voltage part when the power on, otherwise you may get an electric-shock.
6. Do not remove, repair and modify this product, otherwise it may lead to electric shock, fire, fault.

Caution

1. The product should not be used in a nuclear facility and human life associated medical equipment.
2. The product may occur radio interference when it used at home. You should take adequate countermeasures.
3. The product gets an electric shock protection through reinforced Insulation. When the product is embedded in the devices and wiring, please subject to the specification of embedded devices.
4. In order to prevent surge occurs, when using this product in the place of over 30m indoor wiring and wiring in outdoor, you need to set the proper surge suppression circuitry.
5. The product is produced based on mounting on the disk. In order to avoid to touch the wire connectors, please take the necessary measures on the product.

6. Be sure to observe the precautions in this manual, otherwise there is a risk of a major injury or accident.
7. When wiring, please observe the local regulation.
8. To prevent to damage the machine and prevent to machine failure, the product is connected with power lines or large capacity input and output lines and other methods please install proper capacity fuse or other methods of protection circuit.
9. Please don't put metal and wire clastic mixed with this product, otherwise it may lead to electric shock, fire, fault.
10. Please tighten screw torque according to the rules. If not, it may lead to electric shock and fire.
11. In order not to interfere with this product to dissipate heat, please don't plug casing around the cooling vent hole and equipment.
12. Please don't connects any unused terminal.
13. Please do the cleaning after power off, and use the dry-cleaning cloth to wipe away the dirt. Please don't use desiccant, otherwise, it may cause the deformation or discoloration of the product.
14. Please don't knock or rub the panel with rigid thing.
15. The readers of this manual should have basic knowledge of electrical, control, computer and communications.
16. The illustration, example of data and screen in this manual is convenient to understand, instead of guaranteeing the result of the operation.
17. In order to use this product with safety for long-term, regular maintenance is necessary. The life of some parts of the equipment is by some restrictions, but the performance of some will change for using many years.
18. Without prior notice, the contents of this manual will be change. We hope these is no any loopholes, if you have questions or objections, please contact us.

Caution of Install & Connection

1. Installation :

1. This product is used in the following environmental standards. (IEC61010-1) [Overvoltage category II, class of pollution 2].
2. This product is used in the following scope: environment, temperature, humidity and environmental conditions. Temperature:0~50°C; humidity:45~85%RH; Environment condition: Indoor warranty. The altitude is less than 2000m.

3. Please avoid using in the following places: The place will be dew for changing temperature; with corrosive gases and flammable gas; with vibration and impact; with water, oil, chemicals, smoke and steam facilities with Dust, salt, metal powder; and with clutter interference, static electric and magnetic fields, noise; where has air conditioning or heating of air blowing directly to the site; where will be illuminated directly by sunlight; where accumulation of heat will happen caused by radiation.
4. On the occasion of the installation, please consider the following before installation. In order to protect heat saturated, please ensure adequate ventilation space. Please consider connections and environment, and ensure that the products below for more than 50mm space. Please avoid to installed over the machine of the calorific value (Such as heaters, transformer, semiconductor operations, the bulk resistance). When the surrounding is more than 50, please using the force fan or cooling fans. But don't let cold air blowing directly to the product. In order to improve the anti - interference performance and security, please try to stay away from high pressure machines, power machines to install. Don't install on the same plate with high pressure machine and the product. The distance should be more than 200mm between the product and power line.

2. Cable caution :

1. Please use specified compensation wire in the place of TC input. Please use insulated TC if the measured device is heated metal.
2. Please use the cable of lesser resistance in the place of RTD input, and the cable (3 wire) must be no resistance difference, but the total length is within 5m.
3. In order to avoid the effect of noise, please put the input signal away from meter cable, power cable, load cable to wiring.
4. In order to reduce the power cables and the load power cables on the effect of this product, please use noise filter in the place where easy to effect. You must install it on the grounding of the disk if you use the noise filter, and make the wiring to be shortest between noise filter output side and power connectors. Don't install fuse and switch on the wiring of Noice filter output side, otherwise it will reduce the effect of noise filter.
5. It takes 5s from input power to output. If there is a place with interlocking actions circuit signal, please use timer relay.
6. Please use twisted pair with a shield for analog output line, can also connect the common-mode coil to the front-end of the signal receiving device to suppress line interference, if necessary, to ensure the reliability of signal.

7. Please use twisted pair with a shield for remote RS485 communication cable, and deal with the shield on the host side earth, to ensure the reliability of signal.
8. This product don't has the fuse; please set according to rated voltage 250V, rated current 1A if you need; fuse type: relay fuse.
9. Please use suitable slotted screwdriver and wire. Terminal distance: 5.0mm. Screwdriver size: 0.6X3.5, length of slotted screwdriver >130mm. Recommended tightening torque: 0.5N.m. Proper cables: 0.25 ~ 1.65mm single cable/multiple core cable
10. Please don't put the Crimp terminal or bare wire part contact with adjacent connector.

II. Model Illustration

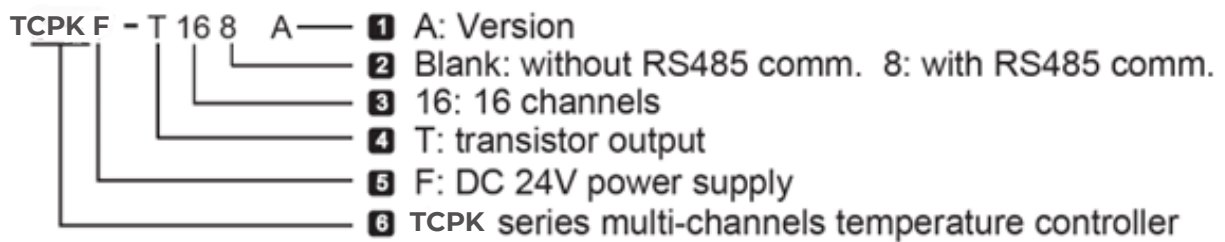

III. Model Description

Model	Control output	RS485
GTDF-T168	Transistor output	Yes
GTDF-T16	Transistor output	No

IV. Specifications

1. Electrical parameters:

Control output	Transistor open collector output level 2
Control output capacity	DC 24V, max 100mA, withstand voltage:100V
Display update rate	1 time per second per channel
Power supply	DC 24V
Power consumption	< 4VA
Environment	Indoor use, temperature: 0-50°C no condensation, humidity<85%RH, altitude<2000m
Storage environment	-10 ~ 60°C, no condensation
Communication port	RS485 port, Modbus-RTU protocol
Insulation impedance	Input/output/power to shell>20M Ω
ESD	IEC/EN61000-4-2 Contact \pm 4KV /Air \pm 8KV perf. Criteria B
Pulse trip anti-interference	IEC/EN61000-4-4 \pm 2KV perf. Criteria B
Surge immunity	IEC/EN61000-4-5 \pm 2KV perf.CriGTeria B
Voltage drop & short interruption immunity	IEC/EN61000-4-29 0% ~ 70% perf.CriGTeria B
Isolation withstand voltage	Circuit between power and other input/output AC1000V,1min
Total weight	About 400g
Shell material	PC/ABS (Flame Class UL94V-0)
Panel material	PVC film and PEM silicone key
Power-off data protection	10 years
Safety Standard	Transistor open collector output level 2

2. Measurement signal parameter

Input Type		Symbol	Measurement Range	Resolution	Accuracy	Input Impedance /Auxiliary current	Communication Code
K	K1		-50~1200	1°C	0.5%F.S. ±3 digits	>500kΩ	0
	K2		-50.0~999.9	0.2°C	0.5%F.S. ±1°C	>500kΩ	16
J	J1		0~1200	1°C	0.5%F.S. ±3 digits	>500kΩ	1
	J2		0.0~999.9	0.2°C	0.5%F.S. ±1°C	>500kΩ	17
E	E1		0~850	1°C	0.5%F.S. ±3 digits	>500kΩ	2
	E2		0.0~850.0	0.3°C	0.5%F.S. ±1°C	>500kΩ	18
T	T1		-50~400	1°C	0.5%F.S. ±3°C	>500kΩ	3
	T2		-50.0~400.0	0.4°C	0.5%F.S. ±3°C	>500kΩ	19
B			250~1800	1°C	1%F.S. ±2°C	>500kΩ	4
R			-10~1700	1°C	1%F.S. ±2°C	>500kΩ	5
S			-10~1600	1°C	1%F.S. ±2°C	>500kΩ	6
N	N1		-50~1200	1°C	0.5%F.S. ±1°C	>500kΩ	7
	N2		-50.0~999.9	0.2°C	0.5%F.S. ±1°C	>500kΩ	20
0~50mV			-1999~9999	12bit	0.5%F.S. ±3 digits	>500kΩ	12

3. Isolation diagram

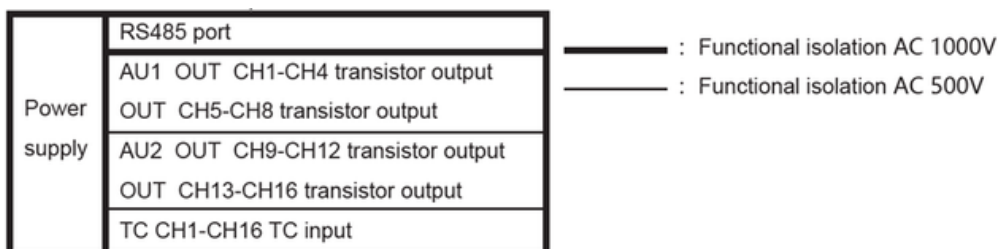

V. Dimensions and Installation method

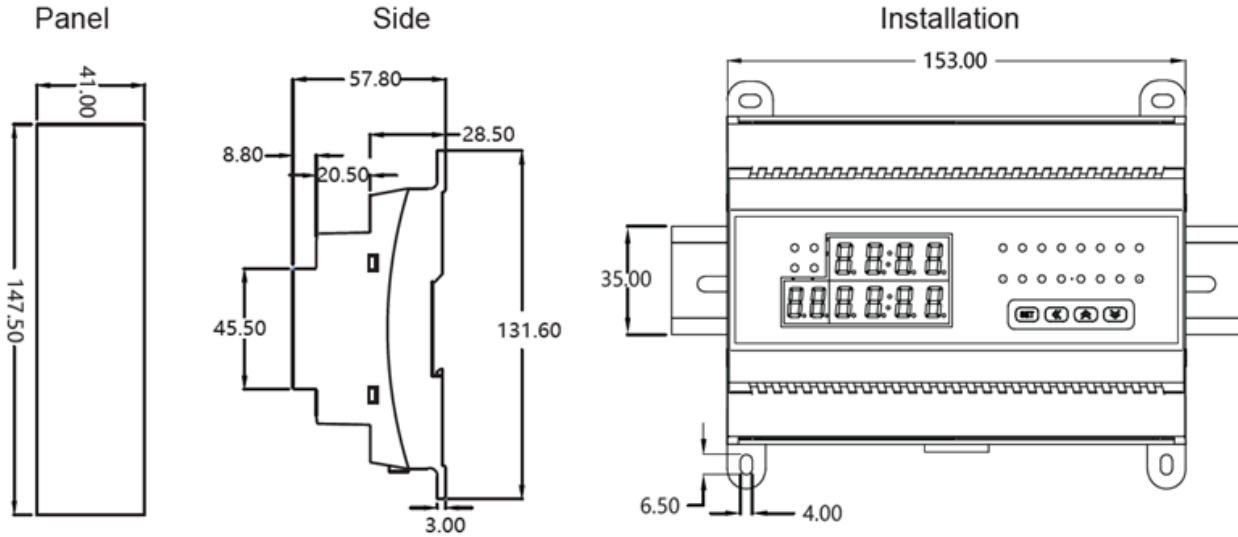

Wire connection

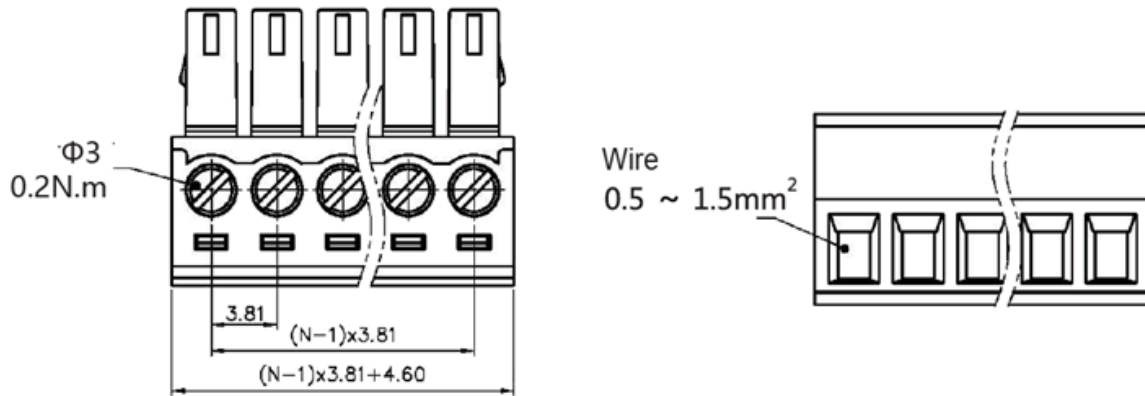

VI. Wiring diagram

1. Wiring marker

+	-	C	E	C	C	C	C	E	E	C	C	C	C	E	E		+	-	+	-	+	-	+	-	+	-	+	-	+	-
POWER		AU2		9 10 11 12 COM3					13 14 15 16 COM4				NC		9 10		11 12 13 14 15 16													
																OUT		TC		INPUT										

RS485			AU1		OUT								NC		TC INPUT															
1	2	3	4	COM1	5	6	7	8	COM2	1	2	3	4	5	6	7	8													
A	B	G	C	E	C	C	C	C	E	E	C	C	C	C	E	E	+	-	+	-	+	-	+	-	+	-	+	-	+	-

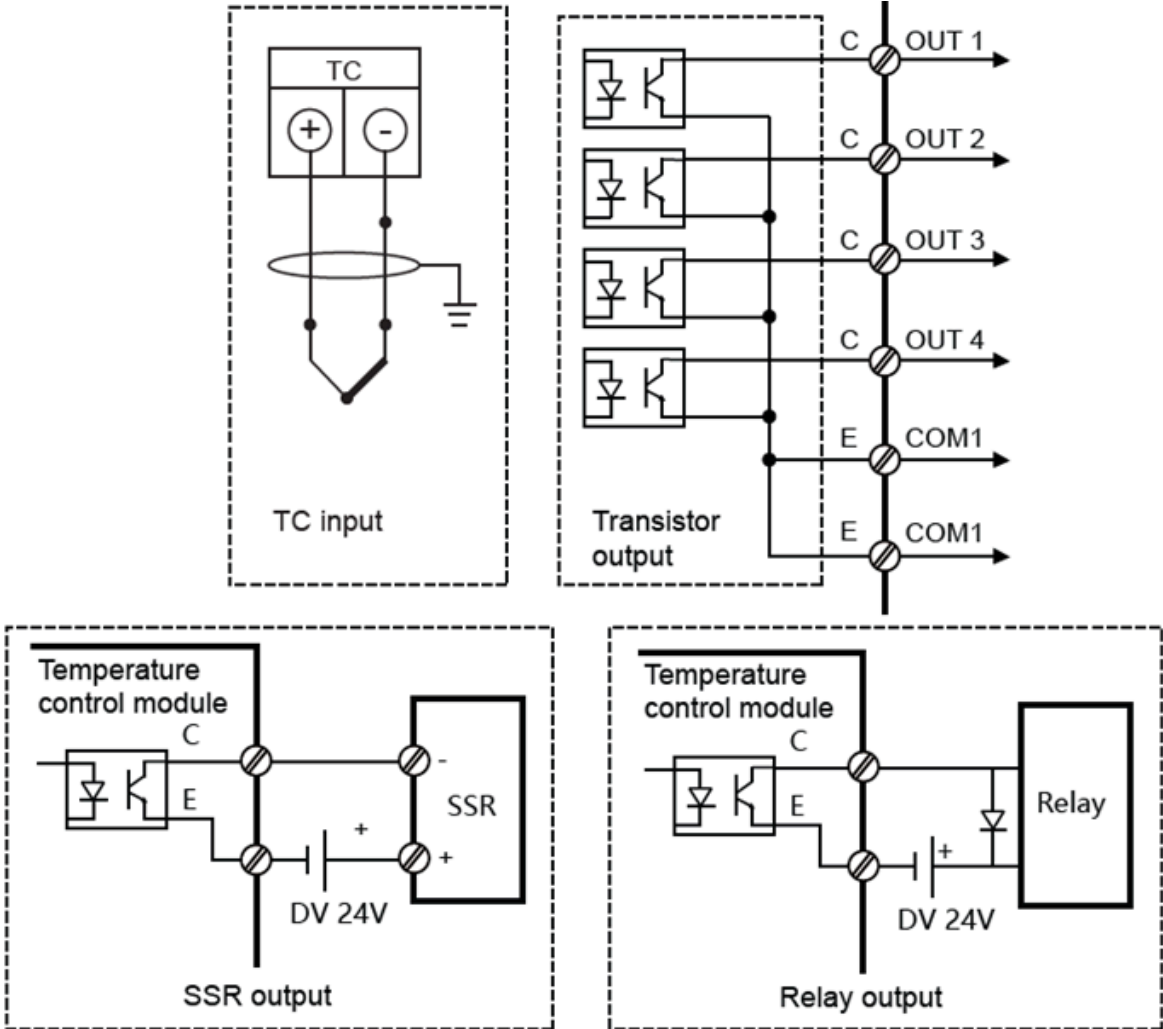

2.Wiring example

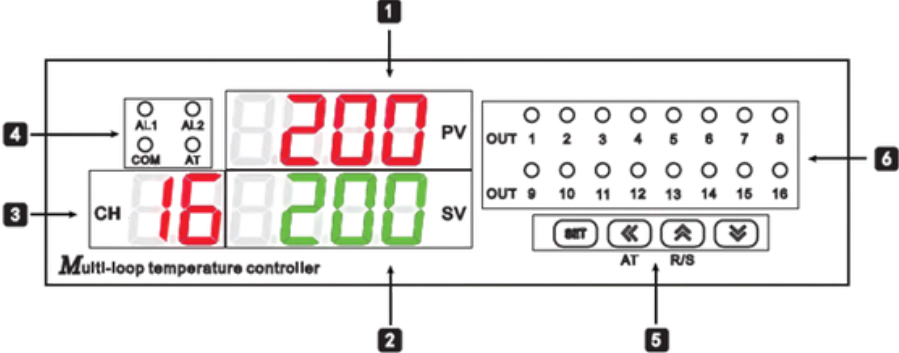

VII. Panel illustration



VII. Name of universal panel

No.	Symbol	Name	Function Description
1	PV	PV display (red)	Measured value or parameter menu symbol
2	SV	SV display (green)	Set value or parameter set value; when it displays “STOP”, control stop.
3	CH	Channel display (red)	Channel number
4	AL1	Alarm 1# indicator (red)	1st alarm indicator, alarm on when the light is on, alarm off when the light is off.
	AL2	Alarm 2# indicator (red)	2nd alarm indicator, alarm on when the light is on, alarm off when the light is off.
	COM	COM indicator (red)	Communication status indicator, after receiving data, the light is on, after sending data, the light is off.
	AT	AT indicator (red)	Auto-tuning indicator, during the auto-tuning process, the light is on.
5	SET	SET key	Menu key/confirm key, press it to enter/exit parameter modification mode, saving modified value, and switch between channels.
		Shift/AT Key	Activation key/shift key/AT auto-tuning key, in measurement control mode, keep pressing it to enter/exit auto-tuning.
		Add key /R/S	Add key/menu up key; in measurement control mode, keep pressing it to switch between RUN & STOP mode.
		Decrease Key	Decrease key/menu down key
6	OUT	CH 1-16 control output	Control output indicator of each channel, output on when the light is on, output off when the light is off.

VIII. Operation Process and Menu Illustration

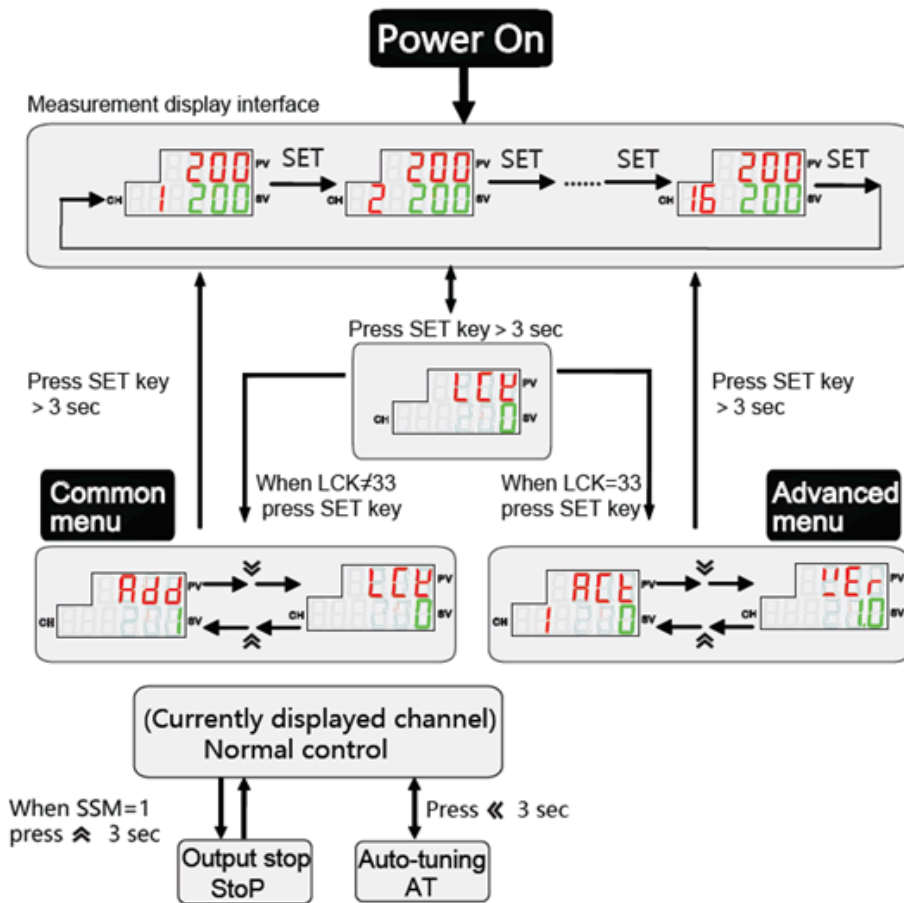

1. Operation process



- In normal measurement control mode, keep pressing “**SET**” key for 3 sec to enter the parameter menu viewing mode, press “**SET**” key to switch the display channel, the channel number is displayed in the CH indication window, parameters displayed on the panel correspond to the displayed channel number.
- In menu viewing mode, press “**▲**” or “**▼**” key to check the common menu parameters circularly.
- In menu viewing mode, press “**◀**” key to flash the viewed menu parameter value to enter the parameter modification mode, and each press of the key can move one bit to the left in cycle.
- In parameter modification mode, press “**▲**” or “**▼**” key once to increase or decrease the flashing data bit by one.
- In parameter modification mode, after the parameter is modified, press “**SET**” key to save the modified value, and keep pressing it for 3 sec to exit to the menu viewing mode.
- In normal measurement control mode, keep pressing “**◀**” key for 3 sec to enter the PID auto-tuning state.
- In normal measurement control mode, keep pressing “**▲**” key for 3 sec to enter/exit the running mode or stop mode; in stop mode, the SV window displays “STOP”.

Note: SSM menu should be set as 1 to enable the operation function.

IX. Menu illustration

-  : No matter what model, what control mode it is, these parameters will be displayed always.
 : According to different model and control mode, these parameters will be hidden.

No.	Symbol	Name	Illustration	Setting range	Factory setting
1	PV	PV	Measuring display value, it will flash or display LLLL/HHHH when the value overflow measure range. Unit: °C/°F or no unit	Refer to measured signal table	No
2	SV	SV	Control item setting value, Unit: °C/°F or no unit	SLL~SLH	200
3	CH	CH	Channel number display window	1 ~ 99	
4	LCK	LCK	Lock function; 0001: SV value cannot be changed; 0010: menu setting value can be read only; 0033: advanced menu can be accessed; 0123: menu restore factory setting	0 ~ 9999	0
5	ADD	ADD	Communication address	1 ~ 247	1
6	BAD	BAD	RS485 communication baud rate 0: 1200 1: 2400 2: 4800 3: 9600 4: 19200 5: 38400 6: 57600 7: 115200	0 ~ 7	3
7	PRTY	PRTY	Communication parity check setting 0: NO 1: ODD 2: EVEN	0 ~ 2	0
8	DATC	DATC	Communication data transport sequence 000; 1st bit function reserved; 2nd bit is byte sequence exchange; 3rd bit function reserved.	Refer to COM protocol	0
9	AL1	AL1	1st alarm value: Negative values are treated as absolute values when used as deviation values.	FL ~ FH	10
10	HY1	HY1	The first alarm hysteresis	0 ~1000	1
11	AD1	AD1(1)	1st alarm mode, note: when AD1=0, close alarm function. When AD1>6, 2nd alarm function is invalid.	0 ~ 12	3
12	AL2	AL2	2st alarm value: Negative values are treated as absolute values when used as deviation values.	FL ~ FH	5
13	HY2	HY2	2nd alarm hysteresis	0 ~1000	1
14	AD2	AD2(1)	2nd alarm mode	0 ~6	4

No.	Symbol	Name	Illustration	Setting range	Factory setting
15	ot	OT	Control mode, 0: ON/OFF heating control, 1: PID heating control, 2: ON/OFF cooling control 3: Reversed, 4: Over temperature cooling output 5: PID cooling	0 ~ 5	1
16	p	P	Proportional band: the smaller the setting value is, the faster the system responds; otherwise, it is slower. Increasing the proportional band can reduce the oscillation, but it will increase the control deviation. Decrease the proportional band can reduce the control deviation, but it will cause oscillation. Unit: corresponding measured value	0 ~ 9999	30
17	i	I	Integral time, the smaller the value is, the stronger the integral action is, otherwise, it is weaker. and the more it tends to eliminate the deviation from the set value. The deviation may not be eliminated if the integral effect is too weak. Unit: s	0 ~ 9999	120
18	d	D	Differential time: The system oscillation can be prevented by reducing the differential action to a suitable value. The larger the value is, the stronger the differential action is. Unit: s	0 ~ 9999	30
19	o's	OVS	Overshoot limit, during PID control process, when PV (measured value) > SV (set value) + OVS (overshoot limit), force to close output. The smaller this value is, the smaller the PID adjustment range is, the worse the control stability is. Please set the appropriate value according to the actual situation. This function is unavailable when it is set to 0	0 ~ 9999	5
20	A-M	A-M	Auto-manual control switch, AUTO (0): auto control only; MAN (1): manual control only;	AUTO~AM	AUTO
21	CP	CP	OUT1 control cycle, 1: SSR control output, 4-200: relay control output. Unit: s	1 ~ 200	1
22	db	DB	Position control hysteresis (Negative return differential control), or cooling control and compressor refrigeration control dead zone. after change the INP setting, please change this parameter according to the decimal point position.	-199.9 ~ 999.9	5.0

No.	Symbol	Name	Illustration	Setting range	Factory setting
23	INP	INP	Optional input signal. see the corresponding table of input signal parameters for details, Note: other relevant parameters to be modified	refer to input signal parameters table (page 2)	K1
24	PS	PS	Amend value, display value = actual measured value + amend value	-1999 ~ 9999	0



2.Advanced Menu

No.	Symbol	Name	Illustration	Setting range	Factory setting
25	ACT	ACT	Control mode, 0~1: SSR output or transistor output	0 ~ 1	0
26	AE1	AE1(2)	1st alarm extension function, refer to alarm extension function table	0 ~ 5	0
27	AE2	AE2(2)	2nd alarm extension function, refer to alarm extension function table	0 ~ 5	0
28	DP	DP	Decimal point setting is effective under the linear signal input	0 ~ 3	0
29	DTR	DTR	PV fuzzy tracking value, properly set this value on some occasions, it can get a more stable control display value, this value is unrelated with actual measured value. Note: after setting this value, when alarm setting value is equal to SV setting value, alarm output operation is subject to actual measured value. Set as 0 to close this function. The temperature input unit: Fahrenheit or Celsius. The linear signal input unit: Engineering Digits	0.0 ~ 2.0 0 ~ 20	1.0
30	SSA	SSM	Press the key on the panel to switch the RUN/STOP operation switch, 0: prohibited, 1: OPEN	0 ~ 1	0
31	SLL	SLL	Low limit of target setting value range	FL ~ FH	
32	SLH	SLH	High limit of target setting value range	FL ~ FH	

SLH

No.	Symbol	Name	Illustration	Setting range	Factory setting
33	FL	FL	Measure range low limit, the setting value must be smaller than measure range high limit.	Refer to measured signal parameter table	0
34	FH	FH	Measure range high limit, the setting value must be more than measure range low limit.		
35	oLL	OLL	Output low limit, limit the output low limit current amplitude. Setting value must be less than high limit setting	-5.0 ~ 100.0	0.0
36	oLH	OLH	Output high limit, limit the output high limit current amplitude. Setting value must be greater than low limit setting	0.0 ~ 105.0	100.0
37	Ft	FT	PV digital filter coefficient, the value larger, the stronger of the filtering effect	0 ~ 255	10
38	Pt	PT	Compressor start delay time, unit: s	0 ~ 9999	0
39	PdC	PDC	PID type selection 0 (FUZ): Advanced fuzzy PID algorithm; 1(STD): Ordinary PID arithmetic	FUZ /STD	FUZ
40	Unit	UNIT	Temperature unit setting °C: Celsius °F: Fahrenheit, note: this unit setting is only for temperature measurement signals, “_”: No unit display	(25)°C (26)°F	(25)°C
41	P-S	PRS	Setting parameter reserve position:0 (EEP): EEPROM with power failure protection; 1(RAM): RAM without power failure protection. Description of setting parameter storage address: EEP and RAM. EEP means that the setting parameters are written into EEPROM and can be permanently saved after power failure. It is generally used for factory setting parameters of equipment. Because EEPROM has the limit of writing times, too many and too frequent writes will be damaged; RAM: it means that the parameters are stored in RAM without writing limit and will not be damaged due to frequent writing. The parameters setting will not be saved when the equipment is powered off. After power on, they will be restored to the parameters saved in EEPROM by the equipment manufacturer.	EEP/RAM	EEP

No.	Symbol	Name	Illustration	Setting range	Factory setting
			It is usually used for parameters frequent writing when communicating with the upper computer PLC. The method of using this parameter is to set this parameter as EEPROM firstly. After the equipment factory has finished debugging the equipment and set the parameters, the parameters are saved in EEPROM, and then PRS is modified into RAM, and the equipment is delivered to the user for use, so as to prevent erroneous modification or long-term communication writing data from damaging EEPROM.		
42	RSS	RSS	RUN/STOP reserve position: 0 (EEP): EEPROM with power failure protection; 1 (RAM): RAM without power failure protection. this parameter using method: if the meter is required to be in stop mode every time when it is powered on, first set RSS to EEPROM, and then set "start stop operation" = STOP. This setting parameter will be saved for a long time; Then set RSS to RAM. When using, the upper computer starts/stops the instrument, which is stored in RAM. After power on again, the instrument still enters STOP mode.	EEP/RAM	EEP
43	LPH	LPH	The actual power of each channel load, used for the total power limit; Unit: KW. When set to 0, this channel doesn't participate in power limitation	0.0~999.9	0.0
44	SLPL	SLPL	Total power limit, limits the power distribution of each participating channel when the total power of channel output controls exceeds the total power limit value; Unit: kW; Set to 0, no power limit function	0.0~999.9	0.0
45	AU1P	AU1P(3)	Auxiliary output 1 programming is used to program the AU1 output function. If equipped, it is effective. Please refer to the auxiliary output function mapping table for details.	0 ~ 32	1
46	AU2P	AU2P(3)	Auxiliary output 2 programming is used to program the AU2 output function. If equipped, it is effective. Please refer to the auxiliary output function mapping table for details.	0 ~ 32	17
47	DN	DN	Display the number of channels, indicating the number of measurement channels actually used by the instrument	1 ~ 16	16

No.	Symbol	Name	Illustration	Setting range	Factory setting
48		DNS	Display the starting channel number, which is used to indicate number of channels 1 in multi-machine application. For example: when DNS=3, CH3~CH6 represent 1~4 channels respectively	1 ~ 84	1
49		DNT	Channel cycle display time, 0 means cancel automatic cycle display, unit: s	0 ~ 99	4
50		VER	Software version.	--	--

(1) Alarm parameter and output logic diagram

Symbol description: "☆" means HY, "▲" means alarm value, "△" means SV value

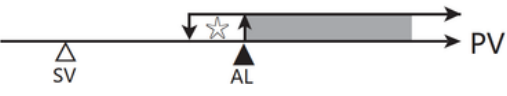
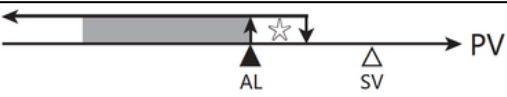
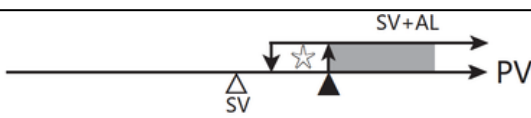
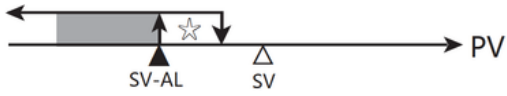
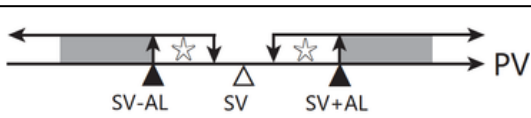
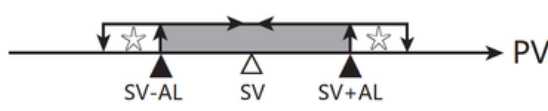
Alarm code	Alarm form	Alarm output (AL1 & AL2 are independent from each other) Image: the hatched section means the alarm action
1	High limit alarm of absolute value	
2	Low limit alarm of absolute value	
3	※High limit alarm of deviation	
4	※Low limit alarm of deviation	
5	※Alarm outside upper /lower limit deviation	
6	※Alarm within upper /lower limit deviation	

※ When a deviation alarm value is set as a negative number, it is treated as an absolute value.

Alarm code	Alarm form	The below two alarm parameters (AL1, AL2) are used in combination, AL1 alarm output, AD2 must be set as 0
1	High and low limit absolute value interval alarm	
2	※High and low limit deviation value interval alarm	
3	※High limit absolute value and low limit deviation value interval alarm	
4	※High limit deviation value and low limit absolute value interval alarm	
5	High/low limit absolute value alarm	
6	High/low limit deviation value alarm	

※ When a deviation alarm value is set as a negative number, it is treated as an absolute value.

(2) Alarm extension function table



AE1/AE2 value	Alarm handling method when it displays HHHH/LLLL	Power on, alarm inhibition
0	Alarm status remains the same	Power on, no alarm inhibition (As long as the alarm condition is met, alarm output immediately.)
1	Forced alarm output	
2	Forced alarm close	
3	Alarm status remains the same	Power on, alarm inhibition (After power on and before the PV value reaches the SV for the first time, the alarm is forced to close, After that alarm work normally)
4	Forced alarm output	
5	Forced alarm close	

(3) Auxiliary output function table

Code	Function	Code	Function	Code	Function	Code	Function
0	NO	9	CH9-AL1	18	CH2-AL2	27	CH11-AL2
1	CH1-AL1	10	CH10-AL1	19	CH3-AL2	28	CH12-AL2
2	CH2-AL1	11	CH11-AL1	20	CH4-AL2	29	CH13-AL2
3	CH3-AL1	12	CH12-AL1	21	CH5-AL2	30	CH14-AL2
4	CH4-AL1	13	CH13-AL1	22	CH6-AL2	31	CH15-AL2
5	CH5-AL1	14	CH14-AL1	23	CH7-AL2	32	CH16-AL2
6	CH6-AL1	15	CH15-AL1	24	CH8-AL2		
7	CH7-AL1	16	CH16-AL1	25	CH9-AL2		
8	CH8-AL1	17	CH1-AL2	26	CH10-AL2		

IX. Key function operation

1. Monitoring mode operation (RUN/STOP):

- SSM is set in open panel operation; Otherwise, the settings only be modified during communication.
- Under the measure mode, long press “” key to enter the STOP mode, SV window will display “STOP”, main control output will stop or keep the minimum output.
- Under STOP mode, long press “” key to exit STOP mode, press “” key to modify SV value.
- Under STOP mode, alarm output and analog output work normally.

2. PID auto-tune operation:

- Before auto-tune procedure, please switch off the control output load power, or set the meter as STOP mode.
- Before auto-tune procedure, PV value should meet below condition: when it is PID heating control, PV needs to be much smaller than SV; when it is PID cooling control, PV needs to be much larger than SV.
- Before auto-tune procedure, please set a proper alarm value or eliminate the alarm condition, in order to prevent the auto-tune procedure from being affected by alarm output.
- Set the PID type and SV value; the factory default setting is fuzzy PID.
- Set as PID control, if there is OLL & OLH output limiting, please set the output to a proper range; factory default setting is OLL=0%, OLH=100%.
- Exit STOP mode, or switch on the load Power, immediately long press “” key to enter auto-tune mode, then the AT indicator light is on.
- The auto-tune procedure will take some time, in order not to affect auto-tune result, please don't modify the parameters or power-off.
- When AT light goes out, it automatically exits auto-tune mode, PID parameters will be updated automatically, and then the meter will control automatically and exactly.

9. During the auto-tune procedure, below actions will cause the termination of the process, long press “◀” key, measure beyond the scope, abnormal display, switch to STOP mode, power-off, etc.
 10. Note: In the occasions with output limiting operation, sometimes, even if the auto-tune is carried out, the best PID parameters still cannot be obtained.
 11. Experienced users can set a proper PID parameter according to their experience.
3. Single channel power limit:
1. OLL and OLH are used to limit the mini to maximum range of the single channel output control amount, which is 0 to 100% by default.
 2. The OLL setting value must be less than the OLH setting value.
 3. If the OLH setting value is too small, the control efficiency and speed will be affected, and the target value may not be reached.
 4. The single-channel power limit cannot realize the total power limit function.
4. Total power limit function:
1. When the actual power LPH setting value of each channel is greater than 0, that is, this channel participates in the function of total power limit SLPL and power even distribution.
 2. If the total power limit value SLPL is set too small, it will affect the control response speed of each limit channel, or even fail to reach the target value. Therefore, it should be set appropriately according to the actual situation.
 3. After setting the LPH and SLPL values, the controller will automatically stagger and distribute the load power evenly to avoid the impact of the simultaneous full power output of each channel on the grid.
 4. The channel that is performing auto-tuning will temporarily exit the total power limit, and will automatically recover after the auto-tuning is completed.

XI. Simple troubleshooting method

Display	How to troubleshoot
LLLL/HHHH	Check whether the input is disconnected; check the FH value and FL value; whether the work temperature is normal & the input signal selection is correct
No display after power on	Check whether the voltage is normal; whether the contact is poor; whether the internal protection of grid harmonics is too high.
No output	Check whether the wiring is correct; whether the contact is bad; whether the ACT/OT menu setting is wrong;
No communication	Troubleshoot hardware connection, instrument settings, software read settings; binary conversion errors; address errors; data errors

XII. Protocol

It uses Modbus RTU communication protocol, read 04 area to keep the register function number be 0x03, write function number 0x10 or 0x06, adopts 16-bit CRC check, it does not return the check error.

The data type is a 16-bit signed or unsigned integer

Data frame format:

Start bit	Data bit	Stop bit	Check bit
1	8	1	None/Odd/Even

1. Read register

Example: The host reads PV1 value (PV1=200)

The register address of PV1 is 0x2000 ("0x" stands for hexadecimal), because the data type of SV is a 16-bit integer (2 bytes), 1 register. The decimal integer 200 is converted to hexadecimal as 0x00C8. Note: When reading data, you should first determine the decimal point position and convert the read data to get the actual value.

Read multiple registers	Device address	Function code	Start ADD High bit	Start ADD Low bit	Data Length high bit	Data Length low bit	CRC code	CRC code
Host request	0x01	0x03	0x20	0x00	0x00	0x01	0x8F	0xCA
Slave responds normally	0x01	0x03	0x02 no. of bytes		0x00	0xC8	0xB9	0xD2
Slave abnormal response	0x01	0x03	0x02 Error code Example: host request add is 0x2011				0xC0	0xF1

2. Write the register

Example: The host writes multiple registers (using function code 10) write SV1 value (SV1=150) The register address of SV1 is 0x2110, because the data type of SV1 is 16-bit integer (2 bytes), 1 register. The decimal integer 150 is converted to hexadecimal as 0x0096. Before writing data, convert the data to the corresponding magnification and then write the data to the meter.

Host request (write multi-register)										
1	2	3	4	5	6	7	8	9	10	11
Meter ADD	Function code	Start ADD High bit	Start ADD Low bit	Data byte Length high bit	Data byte Length low bit	Data byte Length	Data high bit	Data low bit	CRC code	CRC code
0x01	0x10	0x21	0x10	0x00	0x01	0x02	0x00	0X96	0x15	0XAC

Slave responds normally (write multiple registers)							
Device Address	Function code	Start ADD High bit	Start ADD Low bit	Data length high bit	Data length low bit	※CRC code low bit	※CRC code high bit
0x01	0x10	0x21	0x10	0x00	0x01	0x0A	0x30

Host write single register (06 function code) write SV value (SV=150)

Write single register	Meter add	Function code	Add high bit	Add low bit	Data high bit	Data low bit	CRC	CRC
Host request	0x01	0x06	0x21	0x10	0x00	0x96	0x02	0x5d
Slave normal responds	0x01	0x06	0x21	0x10	0x00	0x96	0x02	0x5d
Slave abnormal responds	0x01	0x86 function code	0x02 error code			0xC3	0xA1	

Communication abnormal handling:

In the case of abnormal response, the highest bit of the function number is set to 1. For example, if the function number requested by the master is 0x03, the corresponding item of the function number returned by the slave is 0x83.

0x01---Illegal function: The instrument with the function number sent by the host does not support it.

0x02---The address is illegal: the register address specified by the host exceeds the allowable range of the instrument parameter address.

0x03---Illegal value: The write data value sent by the host exceeds the allowable range of the instrument.

Instrument parameter address mapping table

No	Address (register number ①)	Parameter name	Parameter Description	Qty	Read/Write	Remark
1	0x2000~0x200F (48193~48208)	PV1~PV16	Measure value	1	R	
2	0x2010~0x201F (48209~48223)	STA1~STA4	Status value	1	R	
Unlisted address reserved						
3	0x2100~0x210F (48449~48464)	MV1~MV16	PID Output value	1	R/W	
4	0x2110~0x211F (48465~48481)	SV1~SV16	Setting Value	1	R/W	

Reserve						
No	Address (register number ①)	Parameter name	Parameter Description	Qty	Read Write	Remark
5	0x2120~0x212F (48481~48496)	RSA1~RSA16	Switch	1	R/W	0: RUN 1: STOP 2: AT ON 3: AT STOP
6	0x2130~0x213F (48497~48512)	SSM1~SSM16	Panel R/S enable switch	1	R/W	0: Banned 1: ON
7	0x2140~0x214F (48513~48528)	SLL1~SLL16	Limit setpoint upper limit	1	R/W	
8	0x2150~0x215F (48529~48544)	SLH1~SLH16	Limit setpoint lower limit	1	R/W	
Unlisted address reserved						
9	0x2200~0x220F (48705~48720)	NP1~INP16	Input type	1	R/W	
10	0x2210~0x221F (48721~48736)	FL1~FL16	Upper range limit	1	R/W	
11	0x2220~0x222F (48737~48752)	FH1~FH16	Lower range limit	1	R/W	
12	0x2230~0x223F (48753~48768)	DP1~DP16	Decimal point	1	R/W	
Unlisted address reserved						
13	0x2300~0x230F (48961~48976)	PS1~PS16	Display correction value	1	R/W	
14	0x2310~0x231F (48977~48992)	FT1~FT16	Display filter coefficients	1	R/W	
15	0x2320~0x232F (48993~49008)	DTR1~DTR16	Show trace values	1	R/W	
16	0x2330~0x233F (49009~49024)	BRL1~BRL16	Transmission output lower limit	1	R/W	Reserved
17	0x2340~0x234F (49025~49040)	BRH1~BRH16	Transmission output upper limit	1	R/W	Reserved
Unlisted address reserved						
18	0x2400~0x240F (49217~49232)	OLL1~OLL16	Output lower limit	1	R/W	
19	0x2410~0x241F (49233~49248)	OLH1~OLH16	Output upper limit	1	R/W	
20	0x2420~0x242F (49249~49264)	UNIT1~UNIT16	Measurement display unit	1	R/W	
21	0x2430~0x243F (49265~49280)	PRS1~PRS16	Set parameter save location	1	R/W	0:ROM 1:RAM
22	0x2440~0x244F (49281~49296)	RSS1~RSS16	RUN/STOP Save Location	1	R/W	

No	Address (register number ①)	Parameter name	Parameter Description	Qty	Read Write	Remark
Unlisted address reserved						
23	0x2500 (49473)	DN	Display channel quantity	1	R/W	
24	0x2501 (49474)	DNS	Display the starting channel number	1	R/W	
25	0x2502 (49475)	DNT	Channel cycle display time	1	R/W	
26	0x2503 (49476)	AU1P	Auxiliary output 1 program	1	R/W	
27	0x2504 (49477)	AU2P	Auxiliary output 2 program	1	R/W	
Unlisted address reserved						
28	0x2600~0x260F (49729~49744)	AL11~AL116	Alarm value	1	R/W	
29	0x2610~0x261F (49745~49760)	AD11~AD116	Alarm method	1	R/W	
30	0x2620~0x262F (49761~49776)	HY11~HY116	Alarm hysteresis	1	R/W	
31	0x2630~0x263F (49777~49792)	AE11~AE116	Alarm expansion mode	1	R/W	
Unlisted address reserved						
32	0x2700~0x270F (49985~410000)	AL21~AL216	Alarm value	1	R/W	
33	0x2710~0x271F(410001~410016)	AD21~AD216	Alarm method	1	R/W	
34	0x2720~0x272F(410017~410032)	HY21~HY216	Alarm hysteresis	1	R/W	
35	0x2730~0x273F(410033~410048)	AE21~AE216	Alarm expansion mode	1	R/W	
Unlisted address reserved						
36	0x2800~0x280F(410241~410256)	OT1~OT16	Control method	1	R/W	
37	0x2810~0x281F(410257~410272)	P1~P16	Proportional band	1	R/W	
38	0x2820~0x282F(410273~410288)	I1~I16	Integration time	1	R/W	
39	0x2830~0x283F(410289~410304)	D1~D16	Differential time	1	R/W	
40	0x2840~0x284F(410305~410320)	OVS1~OVS16	Overshoot limit	1	R/W	

No	Address (register number ①)	Parameter name	Parameter Description	Qty	Read Write	Remark
Unlisted address reserved						
41	0x2900~0x290F(410497~410512)	CP1~CP16	Main control cycle	1	R/W	
42	0x2910~0x291F(410513~410528)	DB1~DB16	Bit control hysteresis	1	R/W	
43	0x2920~0x292F(410529~410544)	AM1~AM16	Automatic hand switch	1	R/W	
44	0x2930~0x293F(410545~410560)	CP11~CP116	Cooling control cycle	1	R/W	Reserved
45	0x2940~0x294F(410561~410576)	PC1~PC16	Cooling scaling factor	1	R/W	Reserved
Unlisted address reserved						
46	0x2A00~0x2A0F(410753~410768)	ACT1~ACT16	Control execution way	1	R/W	
47	0x2A10~0x2A1F(410769~410784)	PT1~PT16	Compressor cooling start delay	1	R/W	
48	0x2A20~0x2A2F(410785~410800)	PDC1~PDC16	PID type	1	R/W	
49	0x2A30~0x2A3F(410801~410816)	LPH1~LPH16	Actual load power (KW)	1	R/W	
50	0x2A40(410817)	SLPL	Total Load Power Limit (KW)			
Unlisted address reserved						
51	0x2F00(412033)	ADD	Communication address	1	R/W	
52	0x2F01(412034)	BAD	Communication baud rate	1	R	
53	0x2F02(412035)	PRTY	Check Digit Selection	1	R	
54	0x2F03(412036)	DATC	Data sending order	1	R	
55	0x2F04(412037)	LCK	Password lock function	1	R	
56	0x2F05(412038)	NAME	Instrument name	1	R	

Instrument parameter address mapping table

Note ①: The register number is formed by converting the address into decimal and adding 1, and then adding the register identification code 4 in front; for example: the register number of the data address 0x2000 is 8192+1=8193 and then adding 4 in front, that is, the register number 48193; Related applications can be seen such as Siemens S7-200 PLC.

Note ②: Channel status indication. When the data bit is 1, it means execution, and when it is 0, it means not executed.

D9	D8	D7	D6	D5	D4	D3	D2	D1	D0
----	AT	HHHH	LLLL	°C	°F	AL2	AL1	----	OUT1

Note ③ : DTC communication data transmission sequence description

DTC: — Reserved

Byte transfer order: When 0, 1, 2, when 1, 2, 1

Reserved

※16-bit CRC check code to obtain C program

```
unsigned int Get_CRC(uchar *pBuf, uchar num)
```

```
{
    unsigned i,j;
    unsigned int wCrc = 0xFFFF;
    for(i=0; i<num; i++)
    {
        wCrc ^= (unsigned int)(pBuf[i]);
        for(j=0; j<8; j++)
        {
            if(wCrc & 1){wCrc >>= 1; wCrc ^= 0xA001;}
            else
                wCrc >>= 1;
        }
    }
    return wCrc;
}
```

Thank you for using
TEMPERATURE CONTROLLER
TCPK16 - 16 CHANNELS



Website



LINE Official

Website : www.mit-trade.com
Email : info.mittrade@gmail.com
Phone : 081-123-2475

PARKARN INSTRUMENT CO.,LTD