

THERMAL MASS FLOW METERS AND CONTROLS



PS300 SERIES

Product Overview

S300 series mass flow controller (MFC) is a high-performance digital gas mass flow controller developed for photovoltaic, semiconductor, vacuum coating and other industries.

This product adopts the industrial-grade advanced flow sensor chip independently developed by the company, combined with the low-voltage loss gas circuit structure and high-precision digital control circuit and algorithm, to achieve high-precision, high-stability and wide-range ratio control over a wide temperature range.

This product is equipped with optional EtherCAT high-speed communication or Modbus RTU-RS485 digital communication, which is convenient for users.

The product is assembled, calibrated and packaged in a 1000-class purification room with a temperature of 24 ± 2 °C. In order to ensure the product quality, its accuracy, repeatability and other performance indicators must be inspected twice before delivery.

 081-123-2475

 www.mit-trade.com

Product Specifications : PS300 series gas mass flow controller

Parameters	
Requirements	Clean, dry and non-corrosive
Gas type	Air, N ₂ , O ₂ , CO ₂ , He, H ₂ , CH ₄ , Ar, etc.
Full scale ^①	(0-10, 20, 50, 100, 200, 500) sccm (0-1, 2, 5, 10, 20, 30, 50) slm
Accuracy	0.3% F.S. ^② (≤30%F.S.) 1.0% S.P. ^③ (>30%F.S.)
Range ratio	50:1
Response time ^④	≤0.5s
Repetition accuracy	±0.2% F.S.
Resolution ratio	≤20sccm, 0.001sccm ≤100sccm >20sccm, 0.01sccm ≤1000sccm >100sccm, 0.1sccm ≤50slm >1000sccm, 1sccm
Leakage rate	≤1×10 ⁻⁹ Pa m ³ /s He (fluorine rubber seal) ≤1×10 ⁻¹¹ Pa m ³ /s He (all metal seal)
Max.withstand pressure	9.8bar
Environmental requirements	
Operating temp.	0-50°C
Operating humidity	10%-90%R.H. (No ice or frost)
Operating pressure ^⑤	≥2slm, 0.5-4bar <2slm, 0.5-6 bar Other working pressure can be customizable.
Storage temp.	-20-85°C
Electric parameters	
Power voltage	DC15-24V
Power consumption	≤2.7W
Starting time	<1s
EtherCAT Digital Signal	
Interface type	RJ45
Address	1 (Default) ~99

Communication interface	
Analog control	0~5V or 4~20mA
Digital control	RS485
Digital signal (RS485)	
Interface type	RJ45, D-SUB9
Traffic rate	9600,38400,115200 (Default)
Protocol	Modbus-RTU
Address	1 (Default) -250
Mechanical parameters	
Connector type	Card sleeve:1/4inch, 1/2inch VCR:1/4inch, 1/2inch Others are optional.
Gas contact material	Fluorine rubber seal: 316L stainless steel,Fluorine rubber, Si, SiO All-metal seal:316L stainless steel
Main material	Foundation:316L Stainless steel Shell:Aluminum alloy
Sealing material	FKM rubber or all-metal seal
Weight	0.85kg

Remarks

- Unless otherwise stated, this product is calibrated under the following conditions: N2, temperature 25 °C, 2.5bar differential pressure (inlet 3.5bar absolute pressure, outlet 1bar absolute pressure), horizontally placed and installed.
- Recommend to install a straight pipe section with proper size at the inlet end, otherwise the accuracy may be deviated.
- Recommend to match the largest possible joint at the inlet and outlet ends to avoid causing additional pressure loss.
 - ① The range shown is optional for N2.
 - ② %F.S.is the percentage of error to full range.
 - ③ %S.P.is the percentage of error to set value.
 - ④ Response time refers to the time required to reach the set value within $\pm 2\%$.
 - ⑤ Working pressure refers to the differential pressure between air inlet and air outlet (1 bar absolute pressure), for more details, pls contact us.

Product Dimensions : PS300 series gas mass flow controller

The external dimensions of PS300 series products are shown in the figure below, and the inlet and outlet of its flow channel are 1/4VCR connectors by default. If the user has other requirements, please explain when placing the order.

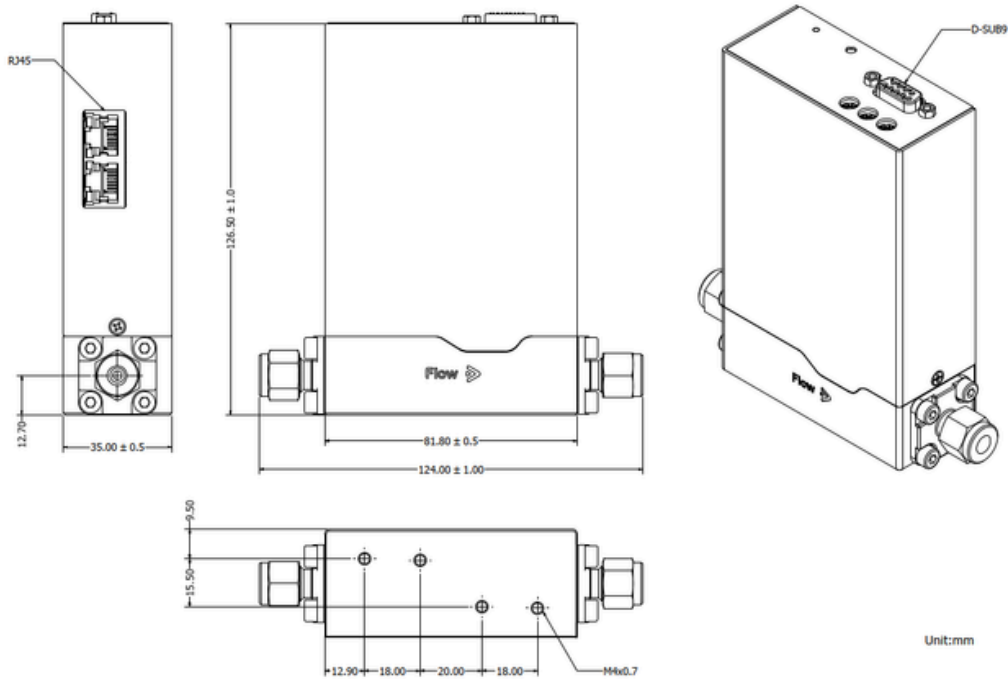

Figure S300 Series Product Appearance Dimensions

Electrical Installation

PS300 series products adopt switching power supply mode and support DC \pm 24V. D-SUB9 (line sequence arrangement is shown in the table) is used as the electrical connector by default. It supports 0~5V analog communication mode and RS485 serial communication mode (Modbus-RTU is used by default). Customers can customize the electrical connection mode according to actual needs.

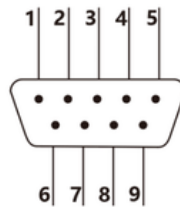

Figure D-SUB9 Pin No.

Table D-SUB9 Line sequence definition

D-SUB9 Equipment end Pin No.	Line sequence definition
1	Please do not connect
2	Analog output
3	Power (DC24v)
4	Power supply ground
5	RS485-A
6	Analog Input
7	Analog ground
8	Analog ground
9	RS485-B

2. Communication Mode

The communication modes of PS300 series products are EtherCAT (default) and Modbus RTU RS-485 (optional, to be explained when ordering), which are connected through the RJ45 interface configured on the top of the product.

The line sequence is defined as follows:

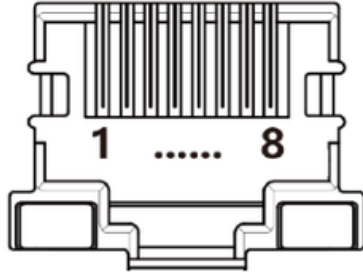

Figure RJ45 equipment end pin serial number

Table RJ45 equipment terminal wire sequence definition.

Pin No.	EtherCAT	RS485(optional)
1	Transmit+	Power supply ground
2	Transmit+	Power supply ground
3	Receive+	Please do not connect
4	Please do not connect	RS485-B
5	Please do not connect	RS485-A
6	Receive-	Please do not connect
7	Please do not connect	Please do not connect
8	Please do not connect	Please do not connect

Model Code : PS300 series gas mass flow controller

Sample Standard Model Code

1	2	3	4	5	6	7	8	9	10
PS300	1	H ₂	20sccm	R4	A	1C	F	NC	1

Code Description	Code Option	Option Description
1.Base Model Numbers	PS300	Advanced Mass Flow
2.Function	1	Mass Flow Controller
	2	Mass Flow Meter
3.Gas type		Air, N ₂ , O ₂ , CO ₂ , He, H ₂ , CH ₄ , Ar, etc.
4.Range	20sccm	0-20sccm
	200sccm	0-200sccm
	500sccm	0-500sccm
	20slm	0-20slm
	30slm	0-30slm
	40slm	0-40slm
	50slm	0-50slm
		Specify flow rate range. (Max. flow rate 50slm)
5.Digital I/O Communication	R4	RS485
6.Analog control	N	None - Digital Communications only
	A	4-20 mA
	V	0-5 Volt
7.Mechanical Connection	1C	1/4" tube compression
	2C	1/2" tube compression
	1R	1/4" VCR
	2R	1/2" VCR
8.O-ring Material	F	Fluoroelastomer (FKM)
9.Valve Type	NC	Normally closed
10.Power Supply Inputs	1	24 Vdc